

A1-HV Series

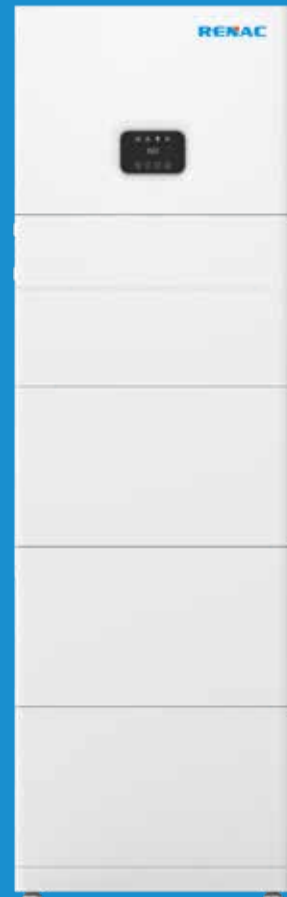

User Manual

A1-HV-3.0

A1-HV-3.68

A1-HV-5.0

A1-HV-6.0

RENAC

Content

1. About This Manual	3
1.1 Applicability	3
1.2 Target group	3
1.3 Symbols used	3
2. Safety	3
2.1 General Safety	3
2.2 Important safety instructions	3
2.3 Explanation of symbols	5
3. Product Overview	6
3.1 Basic features	7
3.2 Work modes	6
3.3 Product Overview	9
3.4 Terminals	10
3.5 Dimension	11
4. Technical data	12
5. Installation	14
5.1 Unpacking	14
5.2 Check for transport damage	17
5.3 Installation precaution	17
5.4 Available space	18
5.5 Preparation	18
5.6 Installation steps	20
5.7 Electrical Wiring Connection	23
5.7.1 PV Wiring Connection	24
5.7.2 Internal Electrical Connection of the Battery	25
5.7.3 AC Output Connection	29
5.7.4 Earth Connection	30
5.7.5 Communication connection	22
5.8 Commissioning	33
5.9 Switch on the Battery System	34
5.10 LED state	34
6. Operation method	34
6.1 Control panel	34
6.2 LCD function	35
6.3 LCD operation	36
7. Troubleshooting	41
8. Decommissioning	43
8.1 Dementling the inverter	43
8.2 Packaging	43
8.3 Storage	43
8.4 Disposal	43

Notice

This manual contains important safety instructions that must be followed during installation and maintenance of the equipment.

Save the manual!

This manual must be stored carefully and be available at all times.

Copyright Declaration!

All rights to the content of this manual are owned by RENAC Power Technology Co., Ltd. (hereinafter called as 'RENAC Power'). Any corporation or individual should not plagiarize, partially copy or fully copy it, and no reproduction or distribution of it in any form or by any means without prior written permission from RENAC Power.

RENAC Power reserves the right of final interpretation. This manual may be updated according to user's or customer's feedback. The information in this manual is subject to change without notice. Please check our website at <http://www.renacpower.com> for latest version.

1. About This Manual

1.1 Applicability

Please read the product manual carefully before installation, operation or maintenance. This manual contains important safety instructions and installation instructions that must be followed during installation and maintenance of the equipment.

A1-HV-3.0 A1-HV-3.68 A1-HV-5.0 A1-HV-6.0

1.2 Target group

This manual is intended for qualified electrical technical personnel who are responsible for All in one ESS installation and commissioning in the energy storage system.

1.3 Symbols used

The following types of safety instructions and general information appear in this document as described below:

	DANGER! 'Danger' indicates a hazard with a high level of risk that, if not avoided, will result in death or serious injury.
	WARNING! 'Warning' indicates a hazard with a medium level of risk that, if not avoided, will result in death or serious injury.
	CAUTION! 'Caution' indicates a hazard with a low level of risk that, if not avoided, could result in minor or moderate injury.
NOTICE	NOTICE! 'Notice' indicates a situation that, if not avoided, could result in equipment or property damage.
	NOTE! 'Note' provides tips that are valuable for the optimal operation of your product.

1.4 Designation in the Document

The following types of safety instructions and general information appear in this document as described below:

Designation in this document	Designation in this document Complete designation
BMC	Battery Master Controller
RBS	Rechargeable Li-ion Battery Stack
SOC	State of Charge
DOD	Depth of Discharge



2. Safety



2.1 General Safety

The All in one ESS has been designed and tested strictly according to international safety regulations. Read all safety instructions carefully prior to any work and observe them at all times when working on or with the All in one ESS. Incorrect operation or work may cause:

- ◆ Injury or death to the operator or a third party;
- ◆ Damage to the inverter or other properties.

2.2 Important safety instructions







	<p>DANGER!</p> <ul style="list-style-type: none"> ◆ PV strings will produce electrical power when exposed to sunlight and can cause a lethal voltage and an electric shock. ◆ Only qualified personnel can perform the wiring of the PV panels. <ul style="list-style-type: none"> ◆ Do not open the enclosure when the inverter is running. Unauthorized opening will void warranty and warranty claims and in most cases terminate the operating license. ◆ When the enclosure lid is removed, live components can be touched which can result in death or serious injury due to electric shock. ◆ Operating a damaged inverter can lead to hazardous situations that can result in death or serious injuries due to electric shock. <ul style="list-style-type: none"> ◆ Batteries deliver electric power, resulting in burns or a fire hazard when they are short circuited, or wrongly installed. ◆ Lethal voltages are present at the battery terminals and cables connecting to the inverter. Severe injuries or death may occur if the cables and terminals in the inverter are touched. <ul style="list-style-type: none"> ◆ PV negative (PV-) and battery negative (BAT-) on inverter side is not grounded as default design. Connecting PV- or BAT- to EARTH are strictly forbidden. ◆ Danger to life due to electric shock when live components or DC cables are touched. <p>The DC cables connected to an inverter may be live. Touching live DC cables results in death or serious injury due to electric shock. Disconnect the battery system and inverter from voltage sources and make sure it cannot be reconnected before working on the device. Do not touch non-insulated parts or cables. Do not remove the terminal block with the connected DC conductors from the slot under load.</p> <p>Wear suitable personal protective equipment for all work on the battery system.</p> <p>observe all safety information of the inverter.</p>
	<p>WARNING!</p> <ul style="list-style-type: none"> ◆ Do not disconnect PV connectors, AC connector or battery connectors while the inverter is running. De-energize from all multiple power sources. Wait 5 minutes for the internal capacitors to discharge. Verify that there is no voltage or current before disconnecting any connectors. <p>Use personal protective equipment, including rubber gloves and protective boots during the installation or maintenance.</p> <ul style="list-style-type: none"> ◆ Battery Module Leakage <p>If the battery modules leak electrolytes, contact with the leaking liquid or gas should be avoided. The electrolyte is corrosive, and the contact may cause skin irritation and chemical burns. If one is exposed to the leaked substance, do these actions:</p> <p>Inhalation: Evacuate the contaminated area, and seek medical help immediately.</p> <p>Eye contact: Rinse eyes with flowing water for 15 minutes and seek medical help immediately.</p> <p>Skin contact: Wash the affected area thoroughly with soap and water and seek medical help immediately.</p> <p>Ingestion: Induce vomiting and seek medical help immediately.</p> <ul style="list-style-type: none"> ◆ The battery modules and its components should be protected from damage when transporting and handling. Do not impact, pull, drag, or step on the battery modules. Do not insert unrelated objects into any part of the battery modules. Do not throw the battery module into a fire. Do not soak the battery modules in water or seawater. Do not expose to strong oxidizers. Do not short circuit the battery modules. The battery modules cannot be stored at high temperatures (more than 50°C). The battery modules cannot be stored directly under the sun. The battery modules cannot be stored in a high humidity environment. Do not use the battery modules if it is defective, or appears cracked, broken or otherwise damaged, or fails to operate. Do not attempt to open, disassemble, repair, tamper with, or modify the battery modules. The battery modules are not user-serviceable. Do not use cleaning solvents to clean the battery modules







	<p>CAUTION!</p> <p>Do not touch any hot parts (such as the heat sink) during operation, The temperature of inverter surface might exceed 60 °C during working</p> <ul style="list-style-type: none"> ◆ Risk of injury due to weight of the battery module <p>Injuries may result if the battery module is lifted incorrectly or dropped-while being transported or installed.</p> <ul style="list-style-type: none"> · Transport and lift the battery module carefully. Take the weight of the battery module into account. · Wear suitable personal protective equipment for all work on the battery system. <ul style="list-style-type: none"> ◆ If the battery is not installed within one month after receiving the battery, the battery must be charged till the SOC is more than 50% for maintains.
NOTICE	<p>CAUTION!</p> <ul style="list-style-type: none"> ◆ Electrical installation and maintenance must be carried out by competent electricians according to local regulations. ◆ Do not open inverter cover or change any components without RENAC Power's authorization, otherwise the warranty commitment for the inverter will be invalid. ◆ Usage and operation of the inverter must follow instructions in this user manual, otherwise the protection design might be useless and warranty for the inverter will be invalid.
	<p>NOTE!</p> <ul style="list-style-type: none"> ◆ Electrical installation and maintenance must be carried out by competent electricians according to local regulations. <p>The inverter built-in RCMU will exclude possibility of DC residual current to 6mA, thus in the system an external RCD (type A) can be used (≥30mA).</p>

2.3 Explanation of symbols

This section gives an explanation of all the symbols shown on the type label.

Symbols on the Type Label

Symbol	Explanation
	TUV mark.
CE	CE mark. The inverter complies with the requirements of the applicable CE guidelines.
	Beware of hot surface. The inverter can become hot during operation. Avoid contact during operation.
	Danger of high voltages. Danger to life due to high voltages in the inverter! Warning! Metal parts of the batteries are always under voltage. Do not short-circuit the batteries! In case of a short-circuit, may flow very high currents and cause burns. By Touching conductive parts can cause cardiac arrhythmia and shock.
	Danger. Risk of electric shock!
	Do not disconnect or disassemble by untrained personnel.
	Do not short circuit.

	Do not expose the battery to open flame, heat or sparks, as there is a risk of fire or explosion.
	Keep the battery modules away from children.
	Observe the documents Observe all documents supplied with the system.
	The battery contains corrosive electrolytes. Please avoid contact with the leaked substance.
	WEEE designation Do not dispose of the system together with the household waste but in accordance with the disposal regulations for electronic waste applicable at the
	Don't work on this inverter until it is isolated from battery, mains and on-site PV generation suppliers.
	Danger to life due to high voltage. There is residual voltage in the inverter which needs 5 min to discharge. Wait 5 min before you open the upper lid or the DC lid.

3. Product Overview

3.1 Basic features

The All in one ESS applies to PV energy storage system with PV module, loads and grid. The energy produced by PV system shall be used to optimize self-consumption, excess power charge battery and the rest power could be fed into the grid. Battery shall be discharged to support loads when PV power is insufficient to meet self-consumption. If both PV power and battery power is insufficient, the system will take power from grid to support loads.

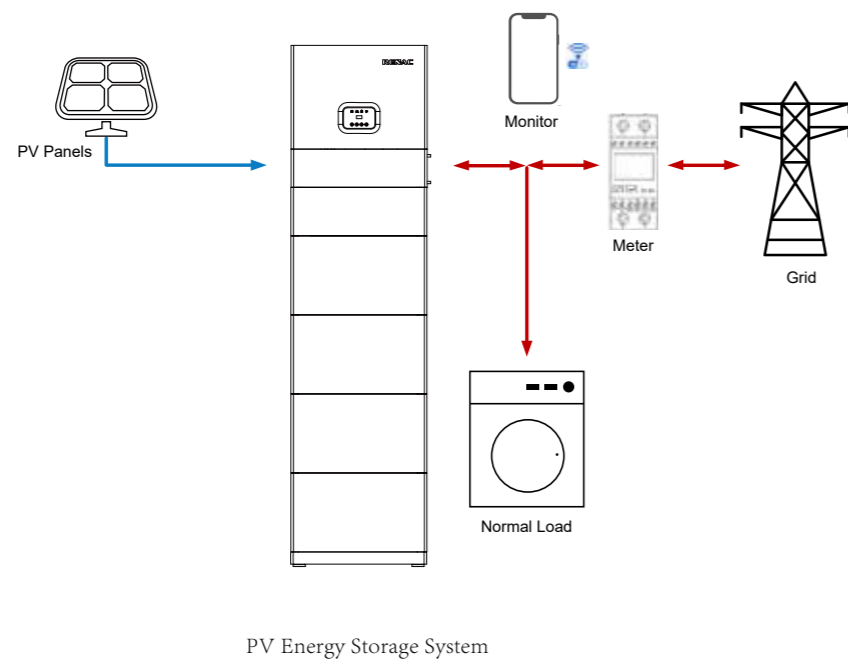

3.2 Work modes

The All in one ESS has the following work modes based on your configuration and layout conditions.

Work mode: Self-use

Priority: load>battery>grid

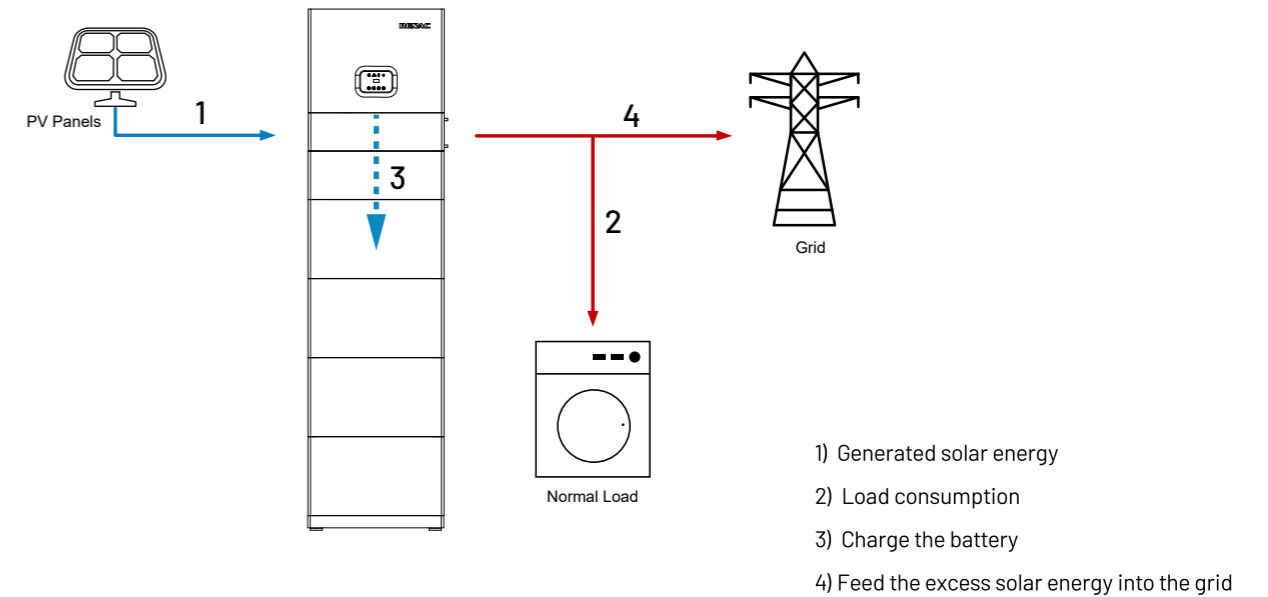

Self-consumption of PV renewable energy is the highest priority. The PV excess is used to charge the batteries, then fed back into the grid.

Work mode: Feed in Priority

Priority: load>grid>battery

This mode applies the area that has high feed-in tariff and export control.

The PV generated power will be used to supply the loads firstly, then feed into the grid. The excess power will charge the battery.

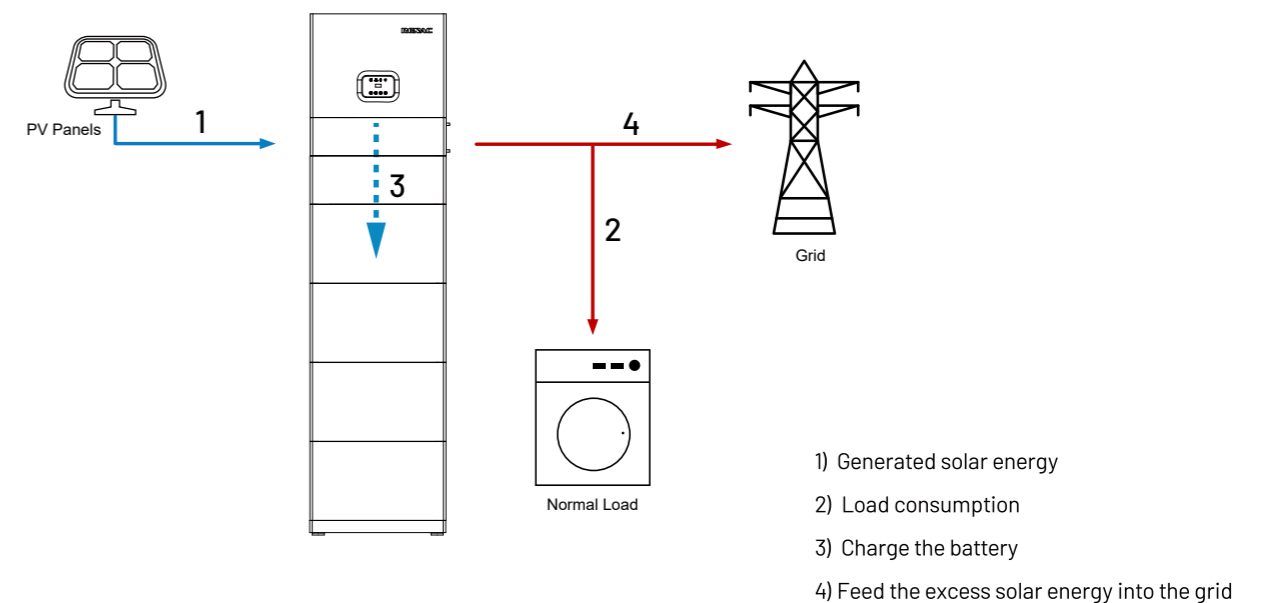

Work mode: Force time use

Priority: battery>load>grid (when charging)

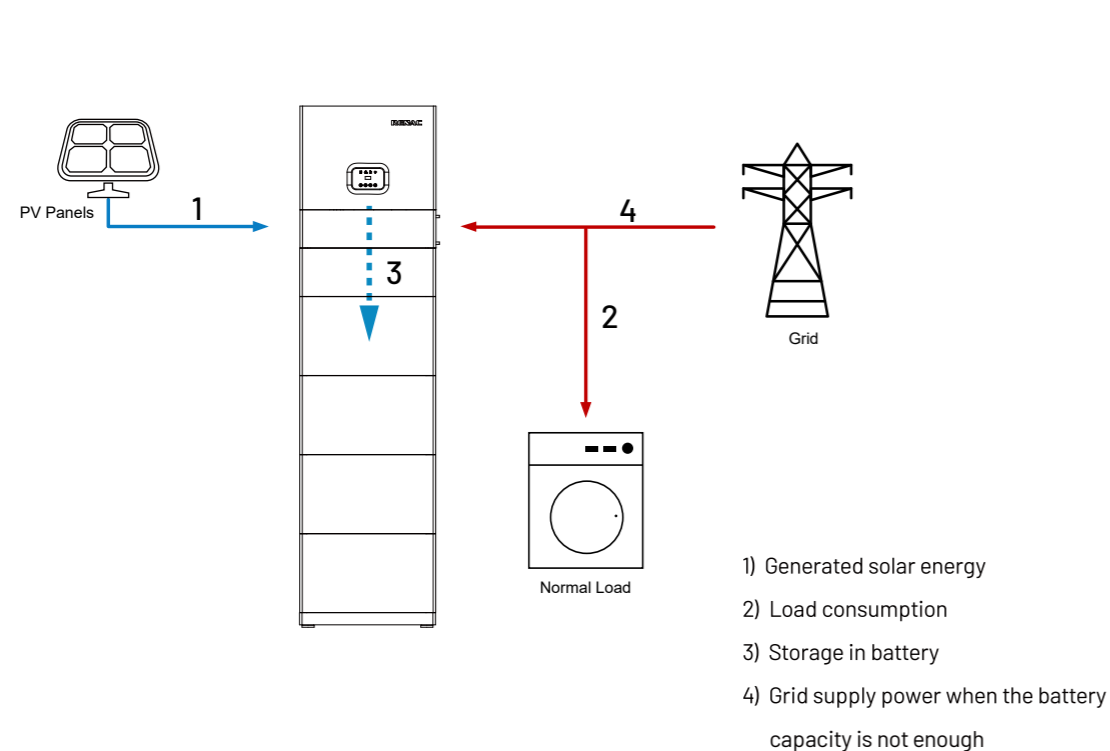

Priority: load>battery>grid (when discharging)

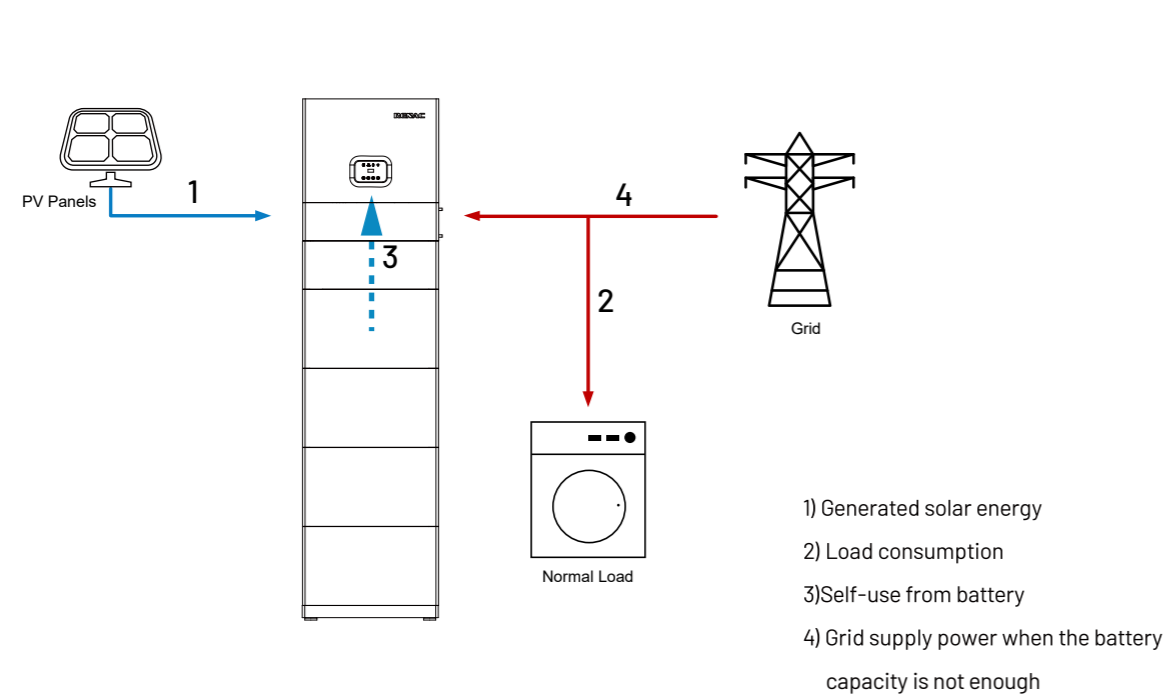

This mode applies the area that has electricity price between peak and valley. User can use off-peak electricity to charge the battery. The charging and discharging time can be set flexibly, and it also allows choosing whether charge from the grid or not.

Work mode: Back up mode

Priority: battery>load>grid

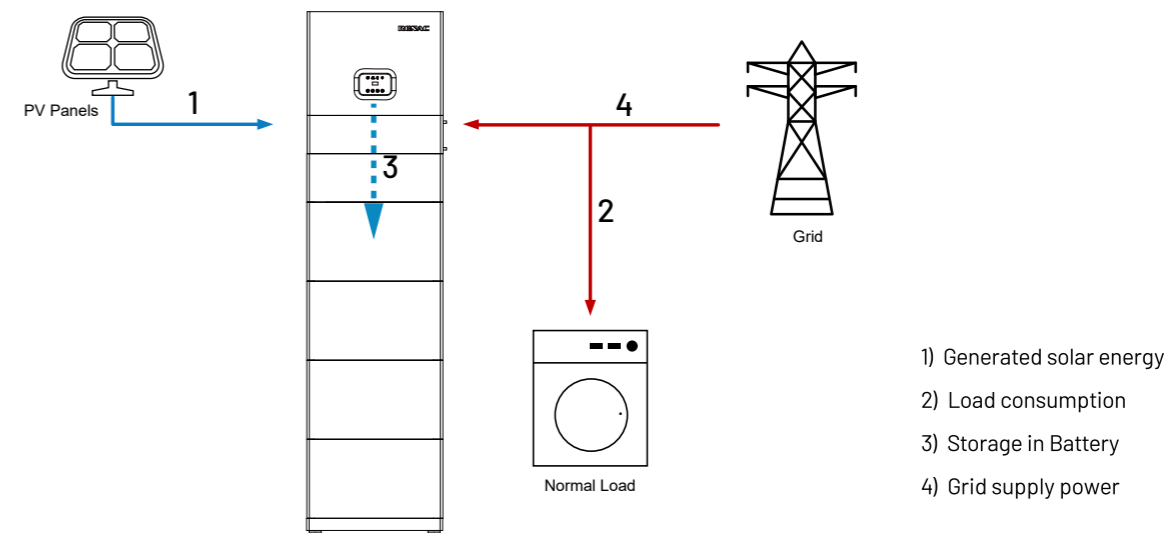

This mode applies the area that has frequent power outages. And this mode ensures the battery will has enough energy to supply during a grid outage. The back up load could be supported by PV and battery in the event of a blackout.

WARNING!
Make sure the load powering rating is within the EPS's output rating. Or the inverter will shut down with an 'over load' warning. When an 'over load' is shown, adjust the load power make sure it is within the range of the EPS output, and turn the inverter on. For the nonlinear load, please pay attention to the inrush power and make sure make sure it is within the range of the EPS output.

3.3 Product Overview

All in one ESS consists of Turbo H1 series battery and N1-HV inverter for PV energy storage system.

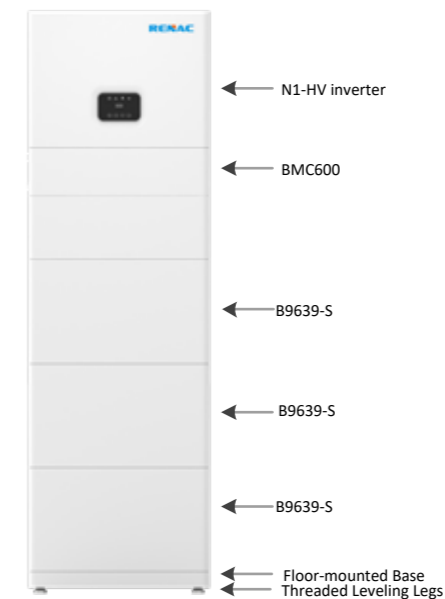

PV Energy Storage System (TB-H1-14.97 is used as example)

3.4 Terminals

Inverter view

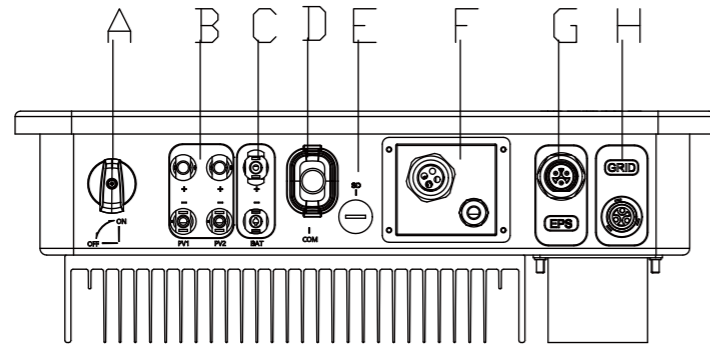

Terminals

Object	Description	Object	Description
A	DC switch	E	SD port
B	PV connector(Only for N1-HV series inverter)	F	Communication port
C	Battery connector	G	EPS port
D	WiFi or GPRS port	H	AC port

BMC view

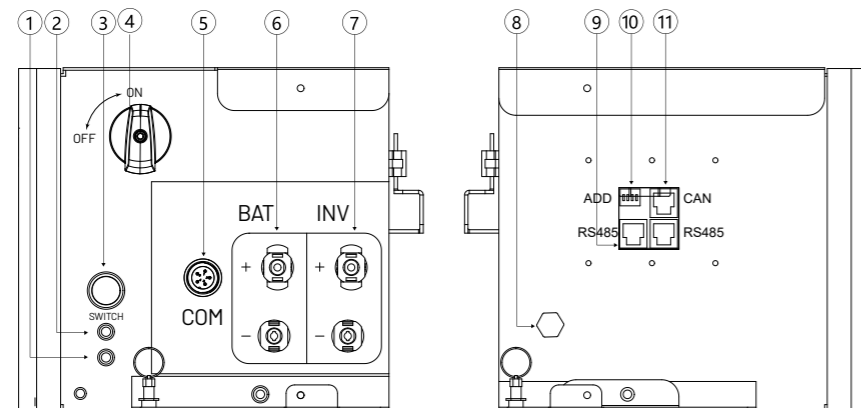

Terminals

Object	Description
1	Alarm LED
2	Running LED
3	Start button
4	DC breaker
5	Communication port
6	Battery terminals connect with B9639-S (BAT+/BAT-)
7	Battery terminals connect with hybrid inverter (BAT+/BAT-)
8	Waterproof valve
9	RS485 port
10	Parallel communication Add
11	CAN port

RBS view

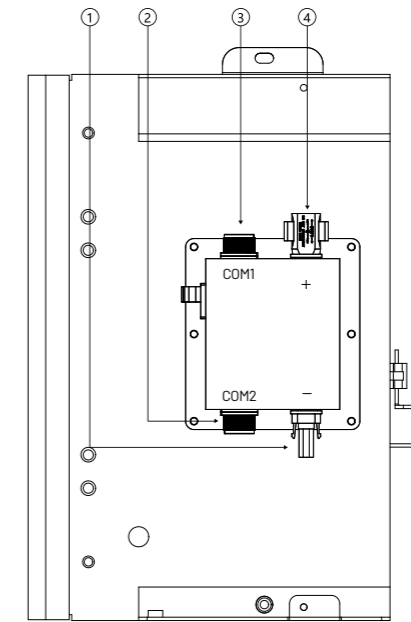

Object	Description
1	BAT- connector
2	CAN communication connector
3	CAN communication connector
4	BAT+ connector

3.5 Dimension

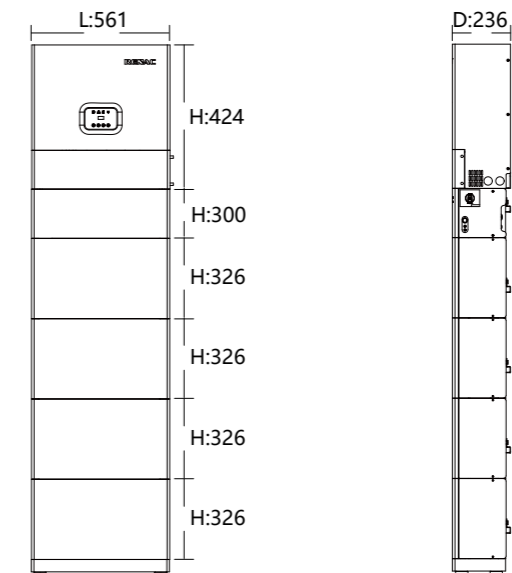

Dimension

4 Technical data

Model	A1-HV-3.0	A1-HV-3.68	A1-HV-5.0	A1-HV-6.0
DC Input Data				
Max. Recommended PV Power [Wp]	4500	5500	7500	9000
Max. DC Input Voltage [V]	600			
MPPT voltage Range [V]	120~550			
Start-up Voltage [V]	150			
No. of MPP Trackers	2			
No. of Input Strings per Tracker	1			
Max. DC Input Current [A]	13.5 / 13.5			
Max. Short-circuit Current per MPPT [A]	17 / 17			
DC Switch	Standard			
Battery Data				
Battery Type	lithium battery			
Recommended Battery Voltage [V]	300			
Battery Voltage Range [V]	85 ~ 450			
Max. Charging / Discharging Power [W]	4500 / 3000	5500 / 3680	6000 / 5000	6000 / 6000
Max. Charging / Discharging Current [A]	25			
Communication Interface	CAN / RS485			
AC Output Data (On-grid)				
Rated AC Power [W]	3000	3680	4600	6000
Max. Output Power [VA]	3000	3680	5000	6000
Max. AC Current [A]	13	16	21.7	26.1
Rated AC Voltage / Range [V]	220 / 230; 180 ~ 270			
Grid Frequency / Range [Hz]	50 / 60; ±5			
Ajustable Power Factor [cos φ]	0.8 leading ~ 0.8 lagging			
Output THDi (@Rated Output)	< 2%			
EPS AC Output Data (Back-UP)				
EPS Rated Power [VA]	3000	3680	5000	6000
EPS Rated Voltage [V]	220 / 230			
EPS Rated Frequency [Hz]	50 / 60			
Max. Output Current [A]	13	16	21.7	26.1
Output THDi (@Rated Output)	< 2%			
Automatic Switch Time [s]	< 0.5			
Peak power, Duration [VA, s]	120% Overload, 600			

Model	A1-HV-3.0	A1-HV-3.68	A1-HV-5.0	A1-HV-6.0
Efficiency				
Max. Efficiency	97.42%	97.45%	97.50%	97.50%
Euro Efficiency	97.15%	97.17%	97.20%	97.20%
Max. Battery Discharge Efficiency(BAT to AC)	97.15%	97.17%	97.20%	97.20%
General Data				
Size (Width*Height*Depth) [mm]	561 x (855+N x 325) x 237 (N ^[1] = 1 ~ 4)			
Weight [kg]	33 + N x 38.7 (N ^[1] = 1 ~ 4)			
User Interface	LCD			
Communication	RS485 (Standard), Wifi or GPRS			
Ambient Temperature Range [°C]	-10 °C ~ 50 °C ^[2]			
Relative Humidity	0 ~ 100%			
Operating Altitude [m]	≤ 2000			
Standby Self Consumption [W]	< 1			
Topology	Transformerless			
Cooling	Natural Convection			
Protection Grades	IP65			
Noise [dB]	< 35			
Warranty [years]	5 / 7 / 10			
Certifications & Standards				
Grid Regulation	AS 4777, EN 50549-1, EN 50549-PL, EN 50549-GR, IEC 61727, CEI 0-21, IEC 62116, C10/C11, VDE0126, ORDINANCE 140			
Safety Regulation	IEC 62109-1, IEC 62109-2, IEC62619, IEC 62040, IEC 62477			
EMC	EN/IEC 61000-6-1, EN/IEC 61000-6-3			

Protection

- DC Insulation Monitoring
- Input Reverse Polarity Protection
- Anti-island Protection
- Residual Current Monitoring
- Over-heat Protection
- AC Overcurrent Protection
- AC Short-circuit Protection
- AC Overvoltage Protection
- DC Surge Protection
- AC Surge Protection

[1] Number of battery modules.

[2] Operating temperature range: Charging(0 ~ +40 °C),Discharging(-10 ~ +50 °C).

5 Installation

5.1 Unpacking

Check the delivery for completeness. Contact your dealer at once if anything is missing.

Inverter



Object	Quantity	Description
1	1	N1-HV/AC series inverter
2	1	Inverter cover
3	1	Inverter bracket(fir fixing the inverter)
4	2	Battery Connectors (1* positive, 1*negative)
5	4	PV Connectors (2* positive, 2*negative)
6	4	PV Pin contact (2* positive, 2* negative)
7	1	AC Terminal
8	1	EPS Terminal
9	1	8P Pluggable Terminal Block
10	1	WiFi or GPRS Module(Optional)
11	3	Ethernet RJ45 Connector
12	6	M5 Screw
13	1	Earth Terminal
14	4	Expansion tubes& Expansion screws
15	1	Meter
16	1	User Manual & Quick installation guide
17	1	Quality Certificate
18	6	M5 Countersunk Screw

Battery Master Controller(BMC)

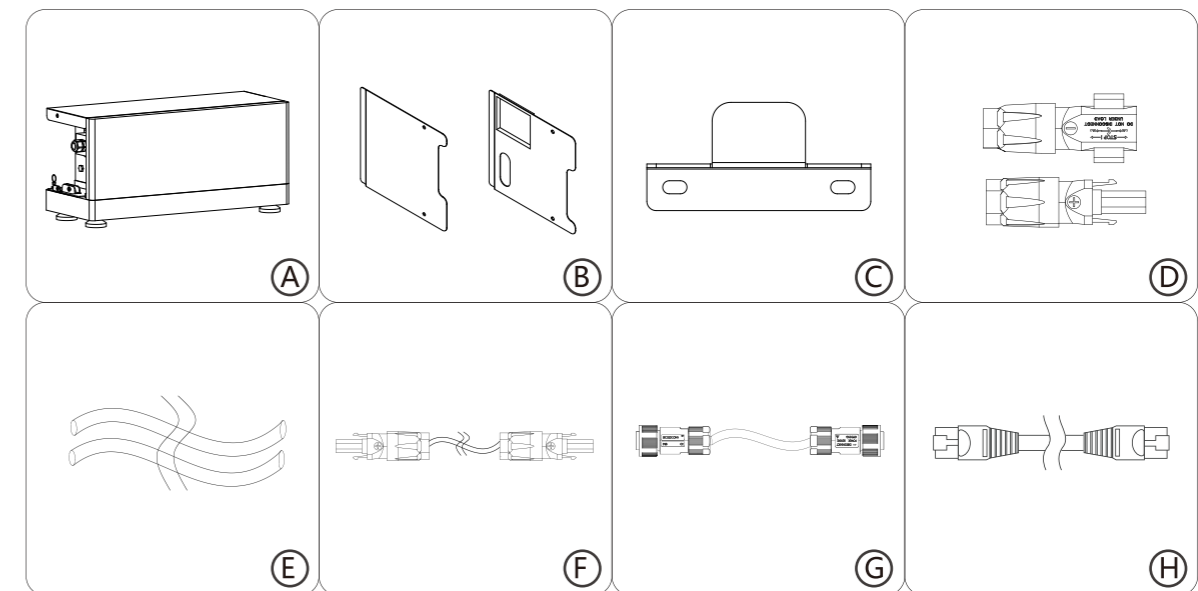

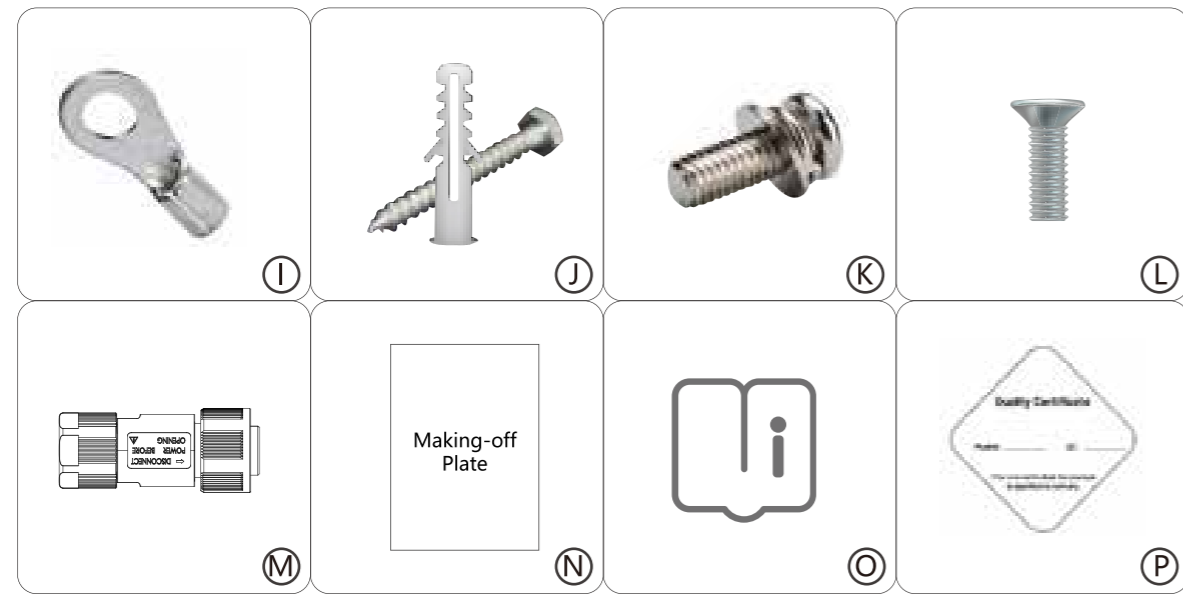

Object	Quantity	Description
A	1	Battery Master Controller (BMC600) with floor-mounted base
B	1	BMC protective cover
C	1	Bracket
D	4	Battery Connectors (1* positive, 3*negative)
E	3	DC input power cable(inverter to battery, 1.5m, B- to B- , 2m)
F	1	DC input power cable (B+ to B+)
G	1	Signal cable (BMC to RBS)
H	1	Signal cable (1.5m)
I	1	Ring terminal (for 10AWG cable) for grounding
J	2	Expansion tubes& Expansion screws
K	4	M5 screws
L	1	M4 screws
M	1	CAN communication terminator resistor
N	1	Making-off plate
O	1	User Manual
P	1	Quality Certificate

Rechargeable Battery Stack(RBS)

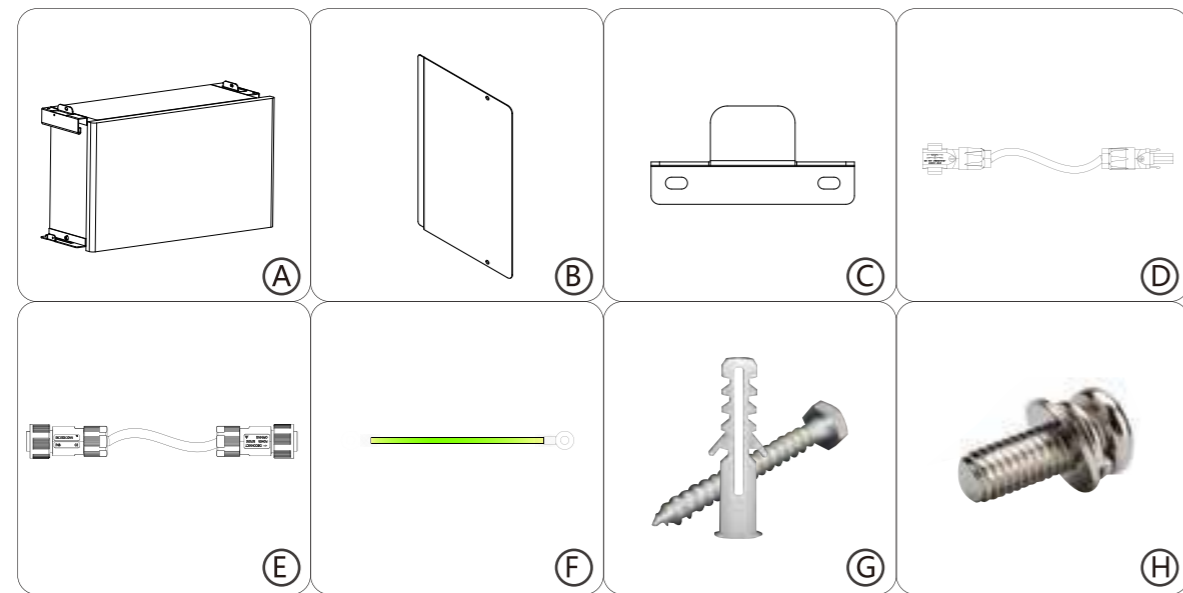

Object	Quantity	Description
A	1	Rechargeable Battery Stack(B9639-S)
B	2	RBS protective cover
C	1	Bracket
D	1	DC input power cable(B+ to B-)
E	1	Signal cable(RBS to RBS)
F	1	Ground cable
G	2	Expansion tubes& Expansion screws
H	5	M5 screws
I	4	M4 screws
J	1	Quality Certificate
K	1	Combiner Box (optional)

Open the package and pick the product, check that if there is any distortion or impaired during the transportation. Meanwhile, check that if the relating accessories and the materials are here, you can see the accessories list in the table.

The instruction manual is an integral part of the unit and should therefore be read and kept carefully.

It is recommended that the packaging should not be removed until the unit is located in the installation site.

5.2 Check for transport damage

Check if the All in one ESS has some visible external damage, such as cracks in the housing or display please contact with your dealer if you find any damage.

5.3 Installation precaution

Requirements for Installation Location



- a) A solid support surface must be available (e.g., concrete or masonry).
- b) The installation location must be inaccessible to children.
- c) The installation location must be suitable for the weight and dimensions of the battery system.
- d) The installation location must not be exposed to direct solar irradiation.
- e) The installation location must not be close to the fire.
- f) The altitude of the installation location should be less than 2000m.
- g) The ambient temperature should be between -10°C and +55°C.
- h) The ambient humidity should be between 5-95%.

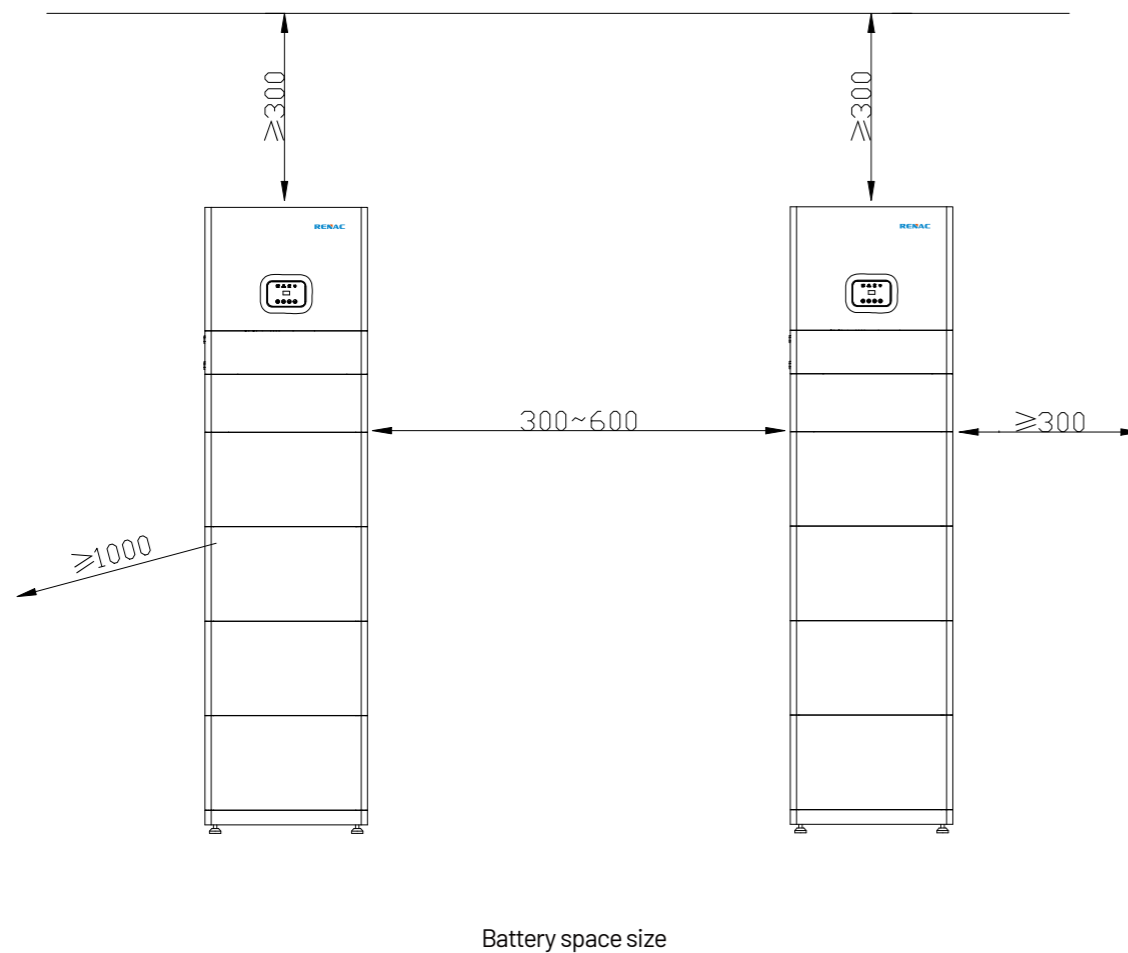

5.4 Available space



5.5 Preparation

No.	Tool	Model	Function
1		Level	Make sure the bracket is properly installed
2		BOSCH HD18-2 Two-Speed Hammer Drill	Drill holes on the wall
3		Hammer	Hanging the bracket

5.5 Preparation

No.	Tool	Model	Function
4		KIMO 20V 1/2 Cordless Brushless Impact Wrench Set	Hanging the bracket
5		PV-AZM-410	Strippling plier for PV cable
6		PV-CZM-22100	Crimping plier for PV cable
7		Screwdriver	Wiring
8		RJ45 Crimping Tool	Crimping tool for RJ45 terminal
9		Crimping plier	Crimping Tool For Insulated Electrical Connectors

Lifting and Handling

The unit is heavy. Do not lift it alone.

- During lifting procedures ensure that the unit is firmly secured to avoid the risk of accidental tipping or dropping.
- Parts serving for support or immobilization of unit shall be designed and manufactured so as to minimize the risk of physical injuries and of accidental loosening of fixing.
- Ensure that the method of lifting will not allow the unit to slip from chains and slings or turn-over or slide from lifting devices.
- Transportation must be carried by specialized person (truck operators, Hook-up personal), equipped with the necessary protection equipment (overalls, safe shoes, protective gloves, helmets, goggles)
- Do not walk or stand beneath or in the proximity of the load.
- Avoid sudden movements and jolts when unloading and positioning the unit. Internal handling procedures must be conducted with care. Do not exert leverage on the components of the machine.

- If the unit is not balanced apply ballast. Any protruding parts should not be supported by hand.
- The inverter should be installed so that the operating panel shall be easily accessible- easy access to the electrical power connection point.
- Accessible for maintenance and repair work.
- Parts serving for support or immobilization of unit shall be designed and manufactured so as to minimize the risk of physical injuries and accidental loosening of fixings.
- Loading capacity and hardness of the supporting surface, load rating of mounting bracket should be at least four times the weight of the devices according to IEC62109-1. And supporting characteristics will be impaired by wear, corrosion, material fatigue or ageing, This should be calculated by inspection of the design data of supporting material and consulting construction engineer.

5.6 Installation steps

- 1.Take the BMC and base out of the package
- 2.Loose the two screws with screwdriver.

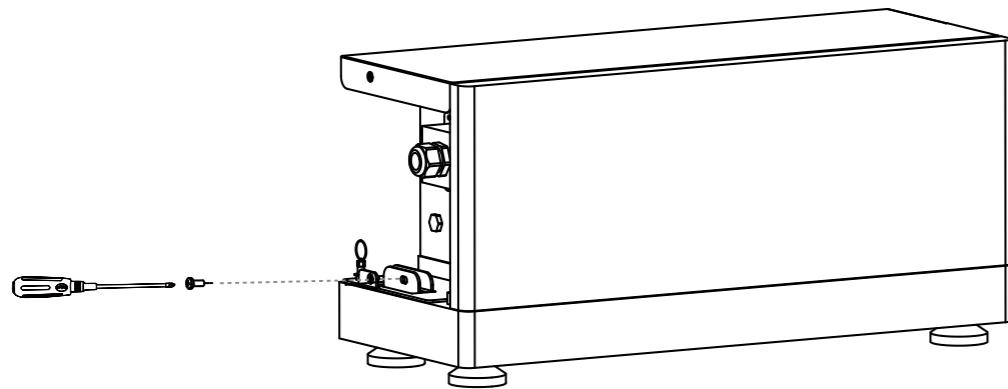

- 3.Take the BMC from the base.
- 4.Put the installed base and feet along the wall, and keep the distance of 20 mm between the wall and the base.

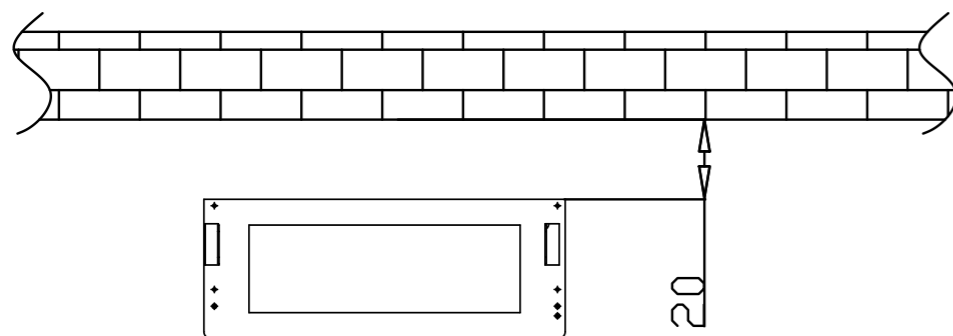

- 5.Align the marking-off plate with the upper surface of the base.

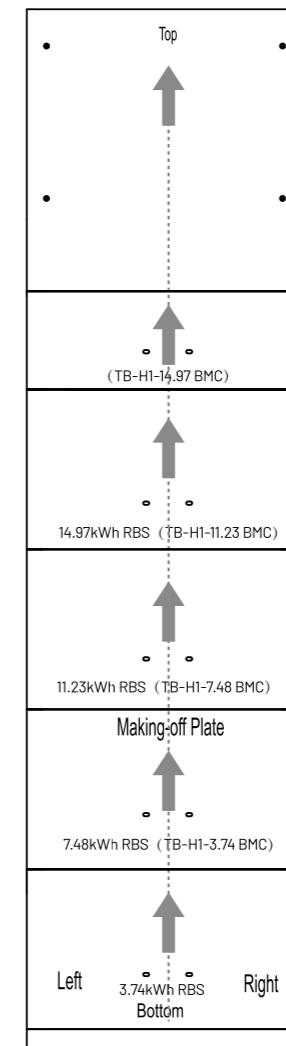

- 6.Drill holes with $\phi 10$ driller carefully, make sure the holes are deep enough(atleast 45mm) for install and tight the expansion tubes.
- 7.Install the expansion tubes in the holes, and tight them. Install the wall bracket using the expansion screws in the screw package.
- 8.Take a battery module from the package out. Hang the RBS on the bracket, Pull the latches on the left and right sides and put one battery module on the base. Pay attention to the direction of the module.
- 9.Repeat the operations for other battery modules.
- 10.Put the BMC on top of the RBSs.

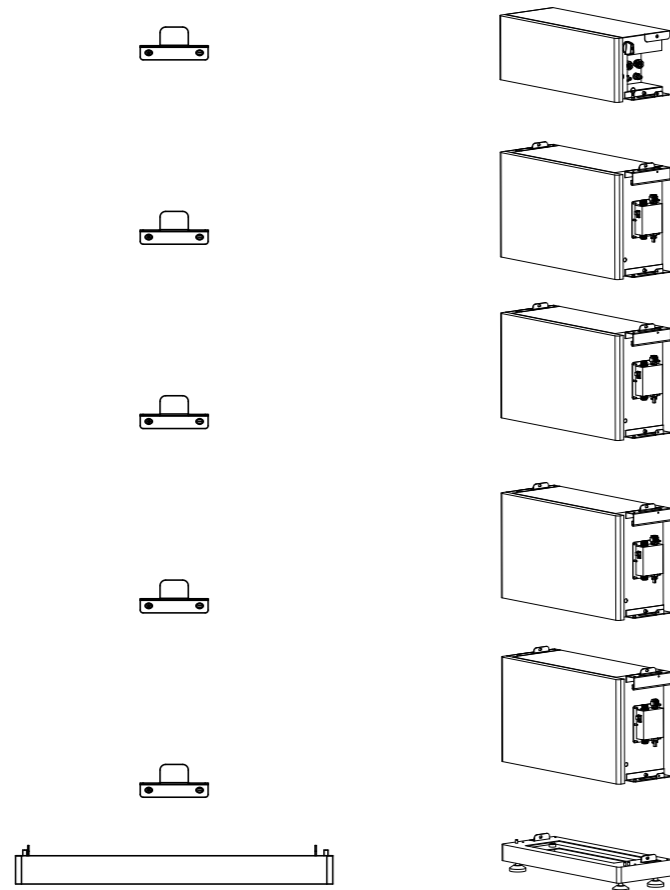

11. Secure the RBSs each other and BMC with RBS using M5 screws

12. Install the frame on the BMC and drill 4 holes to screw the wall bracket on the wall.

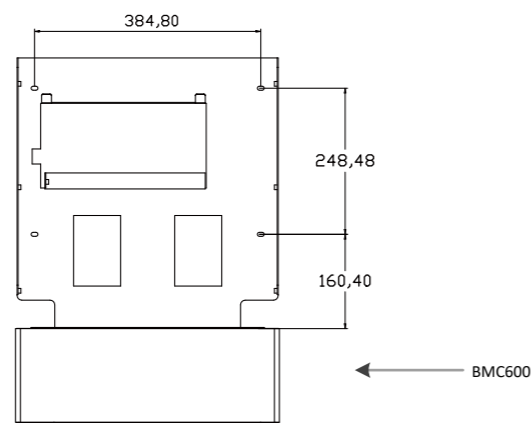

- Drill holes with $\phi 10$ driller carefully, make sure the holes are deep enough (at least 45mm) for install and tight the expansion tubes.
- Install the expansion tubes in the holes, and tight them. Install the wall bracket using the expansion screws in the screw package.

13. Install the inverter bracket and hang the N1 HV inverter

- Transportation of the inverter needs at least 2 people, each one needs to use the handles at the sides of the inverter.
- Hang the inverter over the bracket, move the inverter close to it, slightly laydown the inverter make sure the 4 mounting bars on the back of the inverter is fixed well with 4 grooves on the bracket.

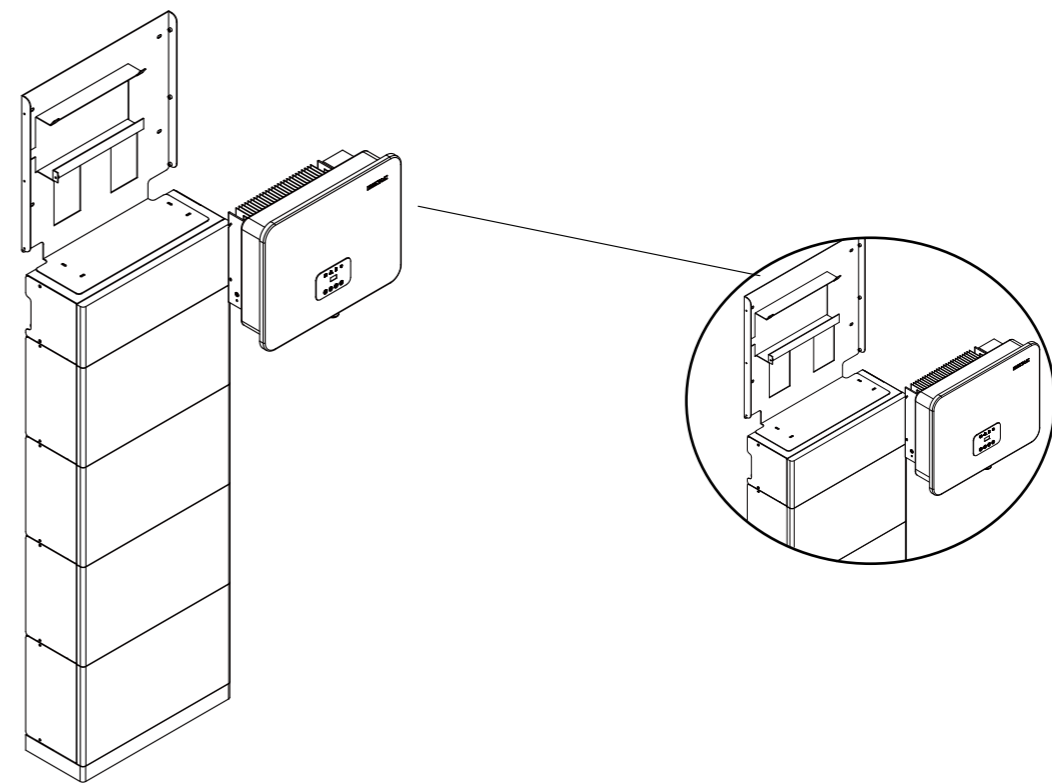

5.7 Electrical Wiring Connection

The overview of the connection terminals of inverter please refer to chapter 3.4 , and the wiring connections please refer to the PV energy storage system wiring diagram in chapter 3.1.

System Connection Diagrams

Note: This diagram is an example for Australian , South Africa and New Zealand grid system where neutral line can't be switched.

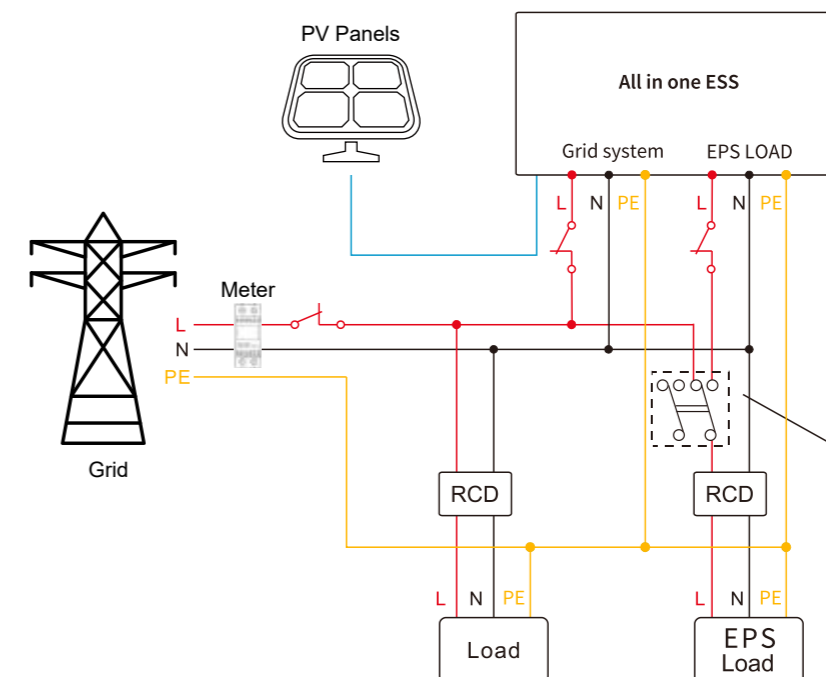

Note: This diagram is an example for grid system without special requirement on electrical wiring connection.

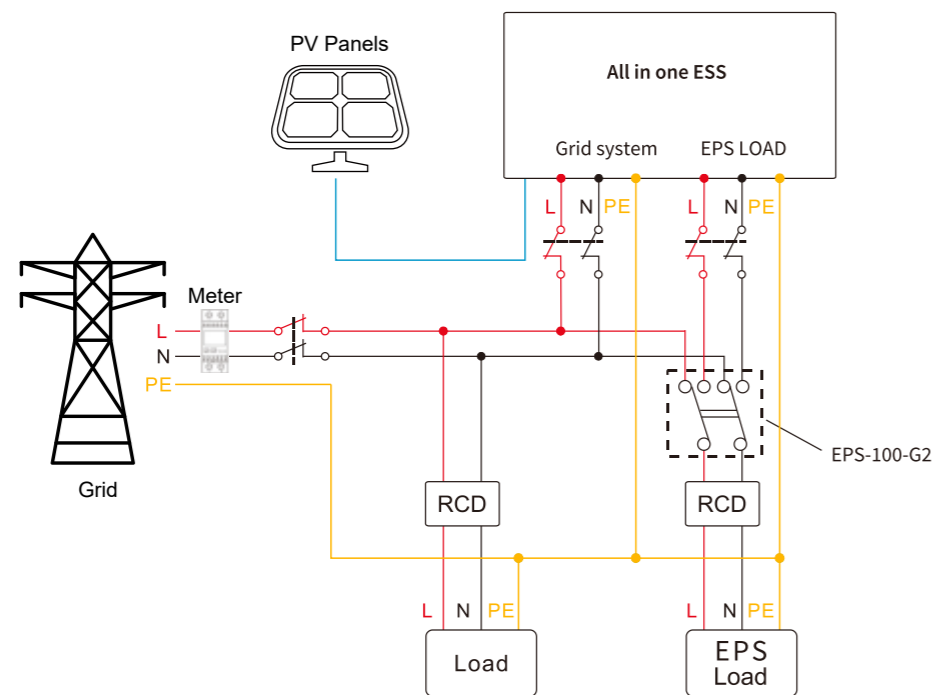

The main steps to connect the All in one ESS system

- PV string connection
- AC output connection
- Battery connection
- Battery power connection
- Battery communication connection
- EPS connection
- Earth connection
- Communication connection

5.7.1 PV Wiring Connection(For All in one ESS inverter)

Before connecting PV strings to All in one ESS inverter, please make sure requirements are followed as below :

- The total short-circuit current of PV string must not exceed inverter's max DC current .
- Make sure open circuit voltage of PV string is less than 600V.
- PV strings could not connect to earth/grounding conductor.
- Use the right PV plugs in the accessory box, BAT plugs are similar with PV plugs, please confirm before use it.

Connection Steps:

1. Turn off the DC switch.
2. Prepare 2.5-4mm² PV cable and PV plugs as below.
3. Strip 7mm of the conductor with stripping plier. Use a suitable stripping tool for this (e.g. "PV-AZM-410 ")

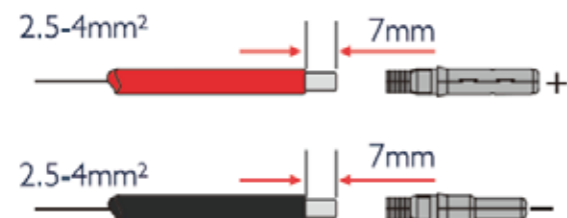

4. Insert striped cable into pin contact and ensure all conductor strands are captured in the pin contact.

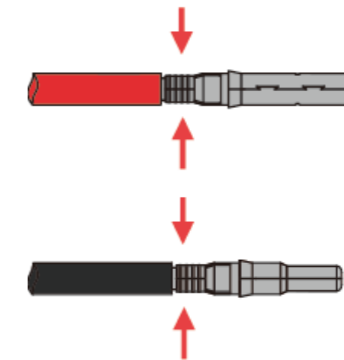

5. Crimp pin contact by using a crimping pliers(PV-CZM-22100). Put the pin contact with striped cable into the corresponding crimping pliers and crimp the contact.
6. Insert pin contact through the cable nut to assemble into back of the male or female plug. When you feel or heard a 'click' the pin contact assembly is seated correctly.
7. Tight the DC connector.
 - a. Slide the cable nut towards the back shell.
 - b. Rotate the cable nut to secure the cable.

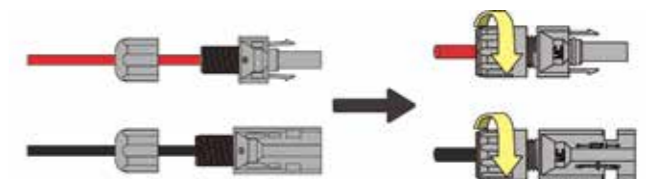
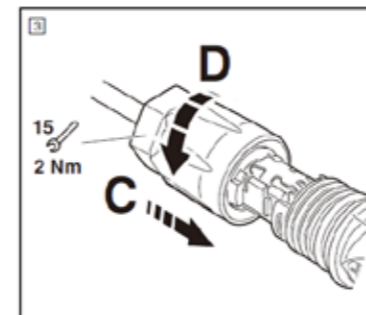

8. After securing the cable tightly, align the 2 half connectors and mate them. together by hand until a 'click' is felt or heard.
9. Separate the DC connector
 - a. Use the specified wrench tool.
 - b. When separate the DC+ connector, push the tool down from upside.
 - c. When separate the DC- connector, push tool down from the bottom side.
 - d. Separate the connectors by hands.

5.7.2 Internal Electrical Connection of the Battery

5.7.2.1 DC power cable Connection

DC power cable(B- to B-) should be prepared by following battery power cable connection, and others cables you can find in the accessory package.

5.7.2.2 Earth Connection

The BMC and RBSs must be connected to a protective conductor. For this purpose, a line from the potential equalization rail to the floor mounted base must be installed expertly Cable size: 10AWG

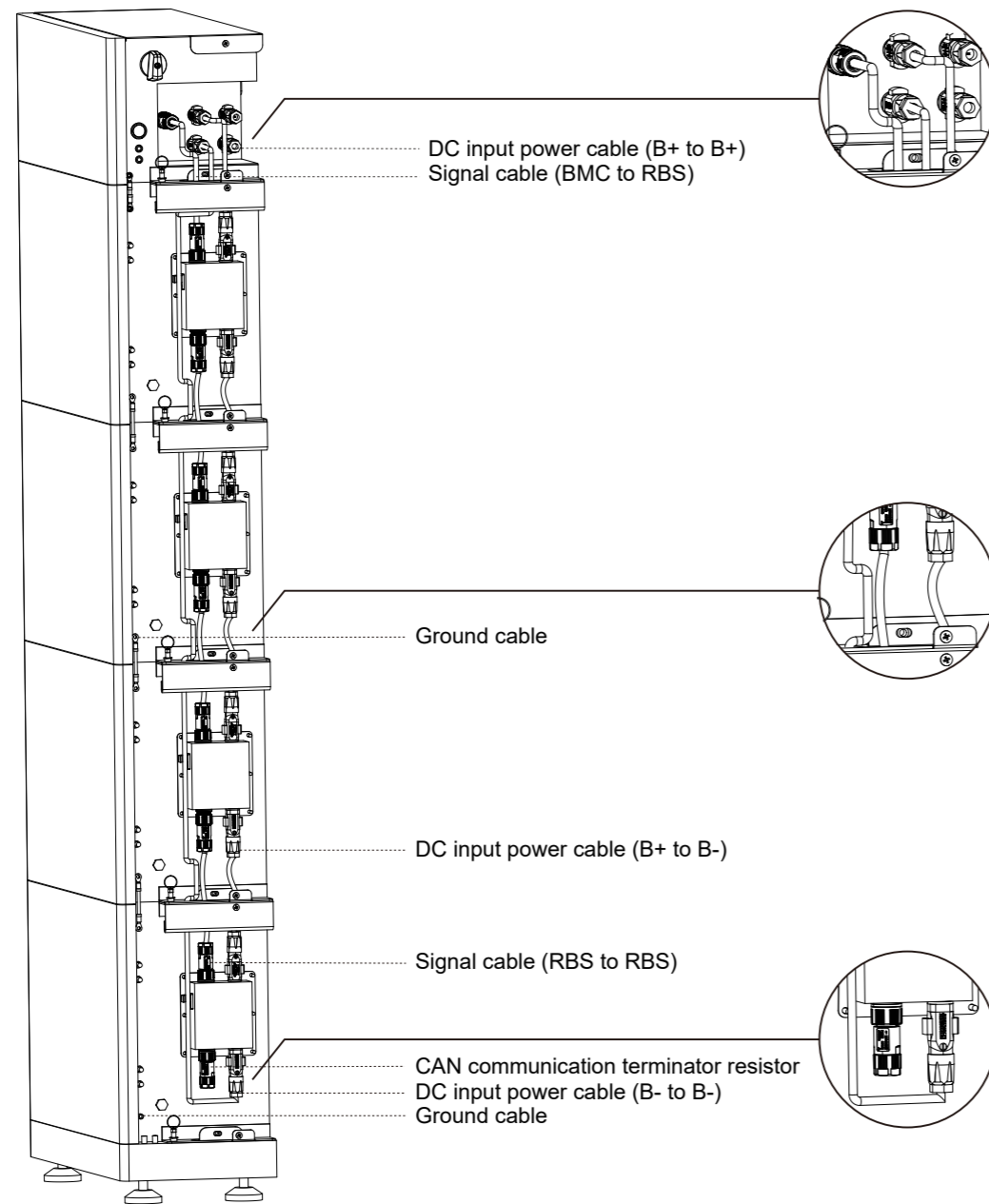

5.7.3 External Electrical Connection of the Battery

5.7.3.1 Battery Power Cable Connection

1. Prepare the tin-plated cables with a conductor cross section of 4 to 6 mm²(AWG 10).
2. Strip 15mm off the conductor. Use a suitable stripping tool for this (e.g. "Knipex Solar 121211").
3. Open the spring using a screwdriver.

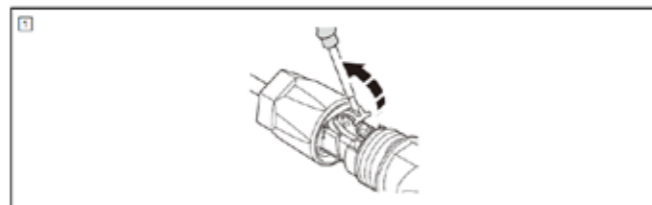

4. Carefully insert the stripped wire with twisted litz wires all the way in (A). The litz wire ends have to be visible in the spring.
5. Close the spring. Make sure that the spring is snapped in (B).

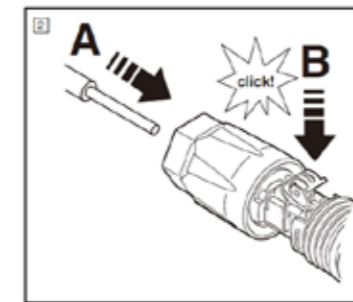

6. Push the insert into the sleeve (C).
7. Tighten the cable gland to 2Nm (D). Use a suitable and calibrated torque wrench, size 15. Use an open-jaw wrench, size 16, to hold the connector in place.

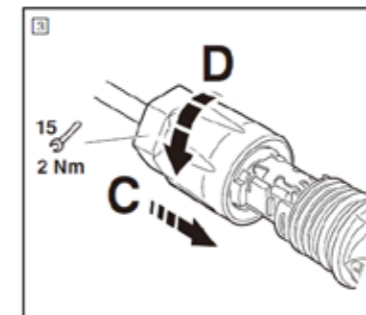

8. Fit the two connectors together until the connection audibly locks into place.
9. Check to make sure the connection is securely locked.
10. Separating connectors
 - 1). Insert the screwdriver into one of the four openings (A).
 - 2). Leave the screwdriver in the opening. Pull the two connectors apart (B).

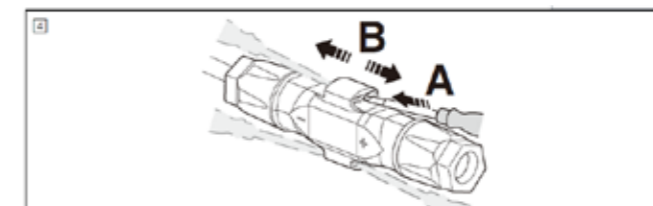

5.7.3.2 Battery Communication Connection

The communication interface between battery and inverter is CAN with aRJ45 connector. The Pins definition is as below.

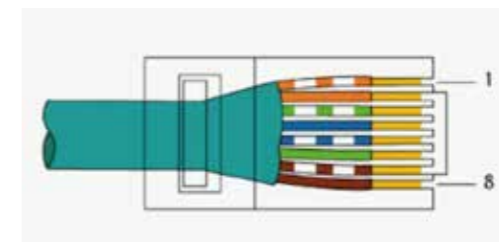

Pin	1	2	3	4	5	6	7	8
Function	NC	NC	NC	CANH	CANL	NC	NC	NC

Overview for all battery connections

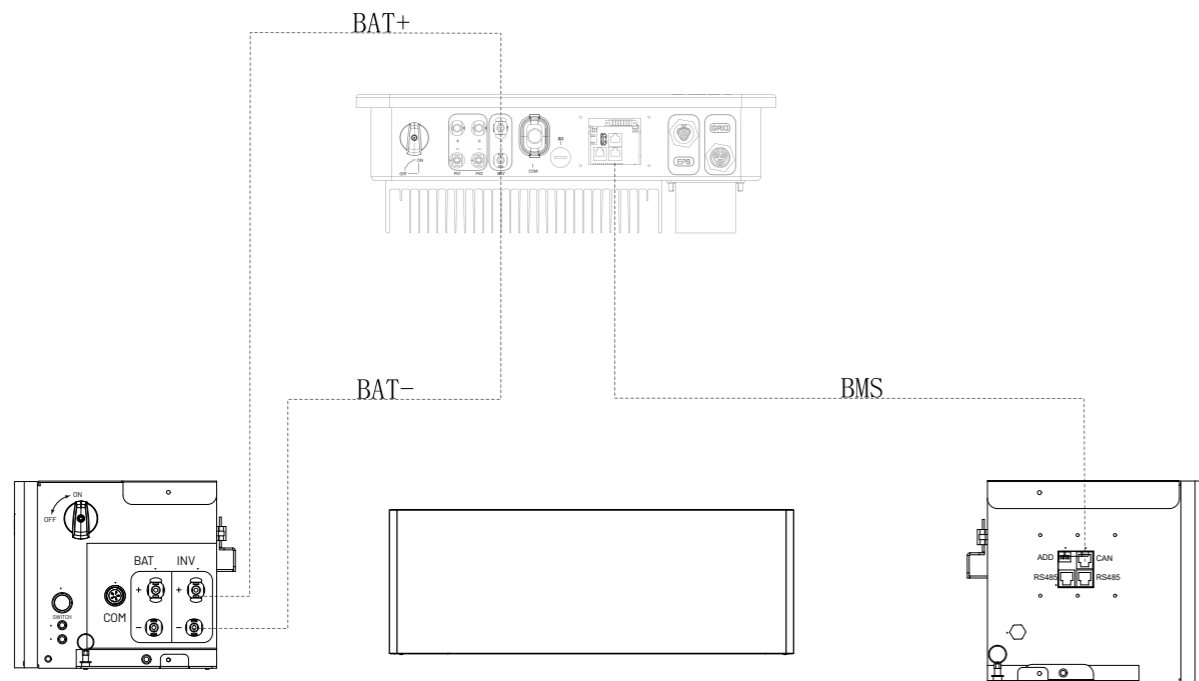

External protective cover installation

After electrical connections are complete, check all the wiring are correctly and securely connected, install the external protective cover, and secure it using M4 screws.

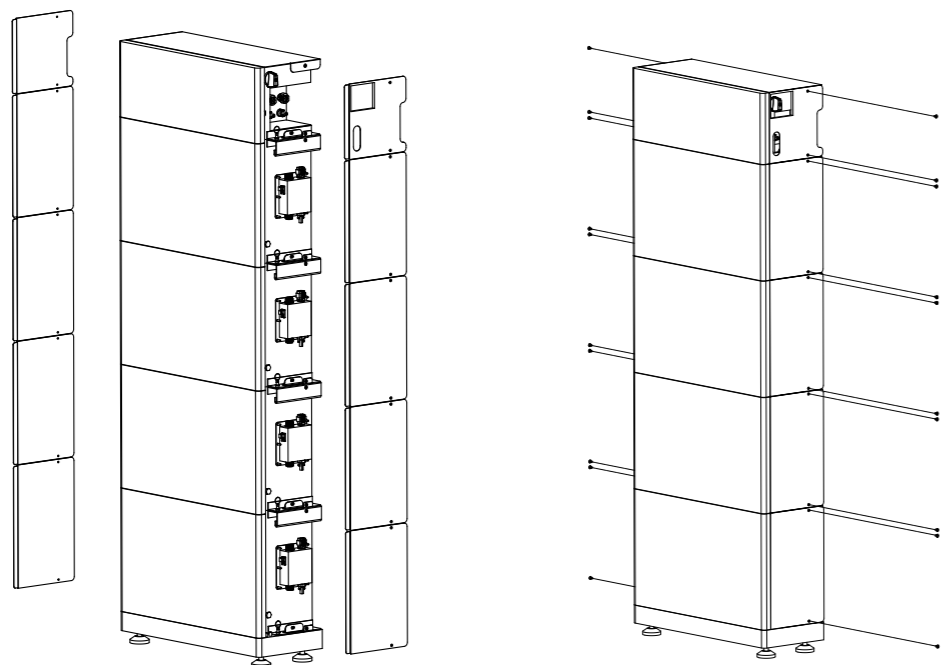

5.7.4 AC Output Connection

All in one ESS inverters have already integrated RCMU (residual current monitoring unit) inside, however if an external RCD is required, a type A RCD with rated residual current of 30mA or higher is recommended. There are two AC terminals and the assembly steps for both are the same, just need to check one for 'Grid' another for 'EPS'. The AC cable and micro-breaker specification for AC side of All in one ESS inverter as below.

Model	A1-HV-3.0	A1-HV-3.68	A1-HV-5.0	A1-HV-6.0
Cable(Cu)	4mm ²	4mm ²	6mm ²	6mm ²
Micro-Breaker	25A	25A	32A	32A

WARNING!
Make sure you select the correct specification cables for installation. Otherwise the power will make the cable hot or burnt; it could result in death or serious injury. Don't connect the phase to 'PE' terminal, otherwise the hybrid inverter will not function properly.

Connection Step:

1. Remove the cable jacket by 40 mm, and strip the wire insulation by 8 mm-15 mm.

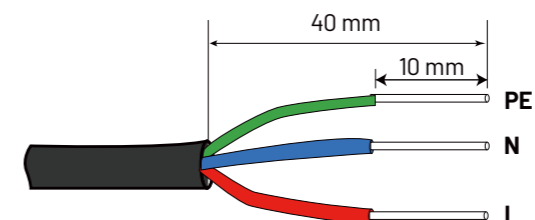

2. Lead the AC cable through the cable gland and the housing.

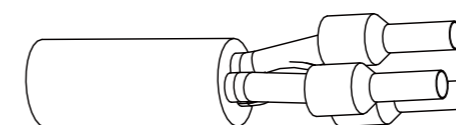

3. Fully insert the conductors to the corresponding terminal and tighten the screws with the torque 0.8 Nm. Pull cables outward to check whether they are firmly installed.

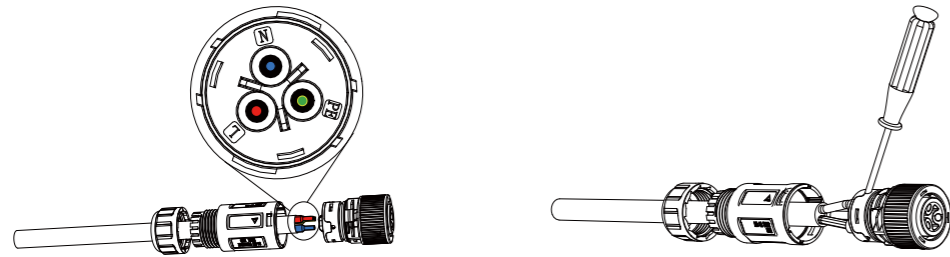

4. Assemble the housing, the terminal block and cable gland (torque 4 Nm-5 Nm). Make sure that the rib of the terminal block and the groove on the housing engage perfectly until a 'Click' is heard or felt.

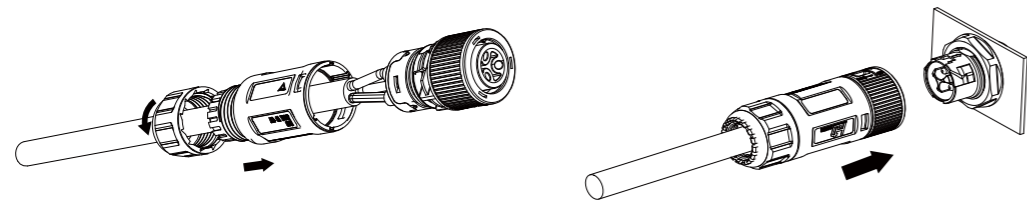

5.7.5 Inverter Earth Connection

You can additionally earth the inverter enclosure of a second earthing or equipotential bonding is required locally. This prevents touch current if the original protective conductor fails. Cable size: 12AWG

Connection step:

- Strip the earthing cable insulation.
- Insert the stripped cable into the ring terminal.
- Clamp the end of the ring terminal.
- Unscrew the screw of the earthing connector.
- Suit the ring terminal on the earthing connector .
- Suit the gasket on the earthing connector.
- Screw the screw of the earthing connector.

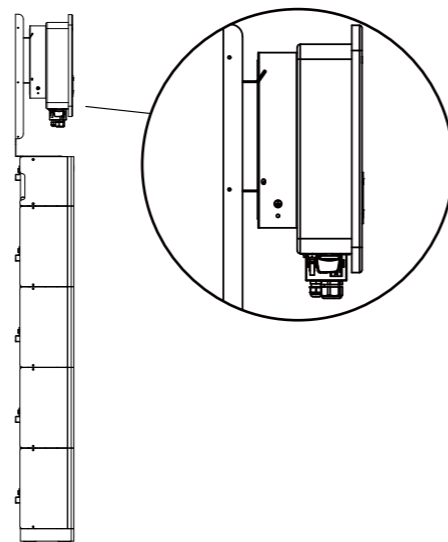

Step 3: Install the inverter cover and terminal cover

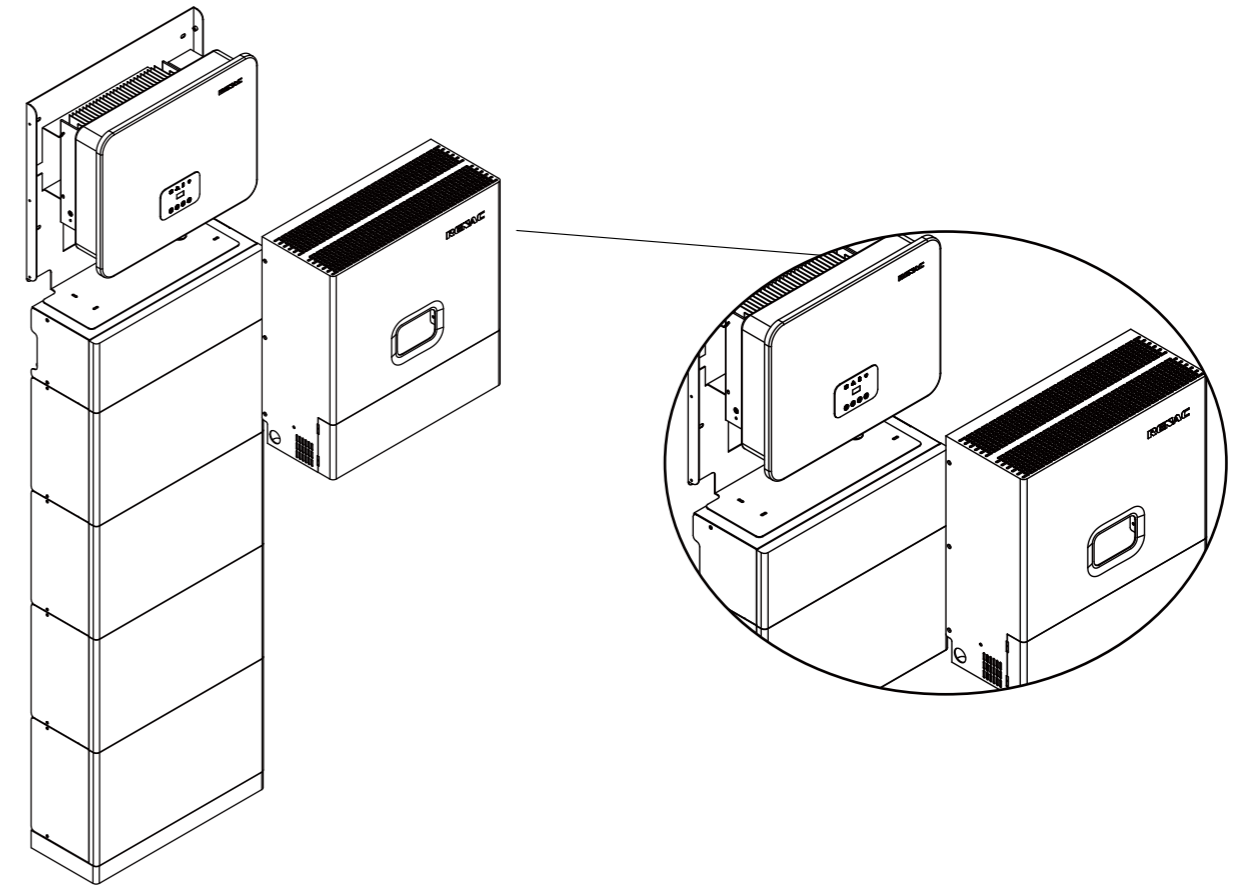

Communication interface

This product has a series communication interfaces besides WIFI or GPRS (optional) , Dry contact and extend port and for human and machine communication, etc., can be delivered to PC or other monitoring equipment via these interfaces.

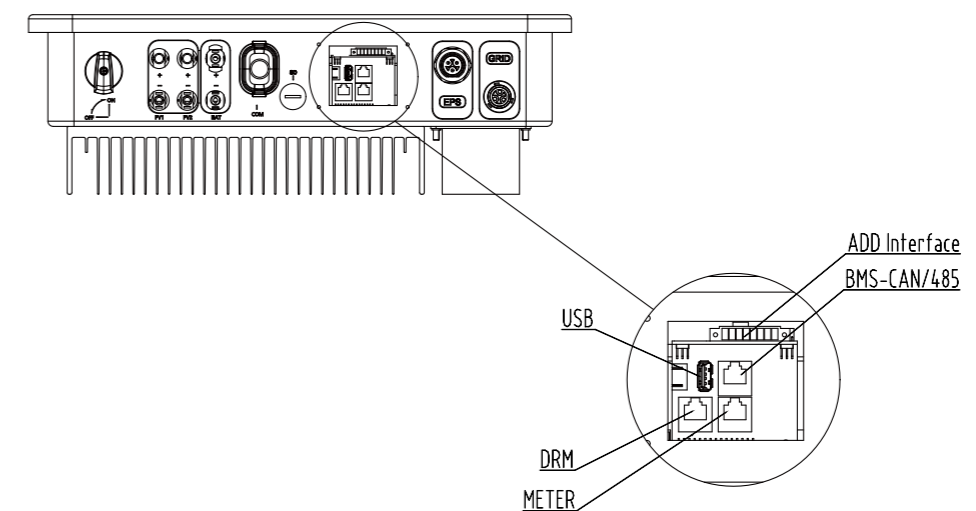

1. WIFI or GPRS

Connect the WIFI/GPRS module produced by Renac to the COM port and install the antenna to the terminal cover. After successful connection, information such as power generation and running state of the inverter can be viewed via the App on the phone. The details please refer to the module user manual.

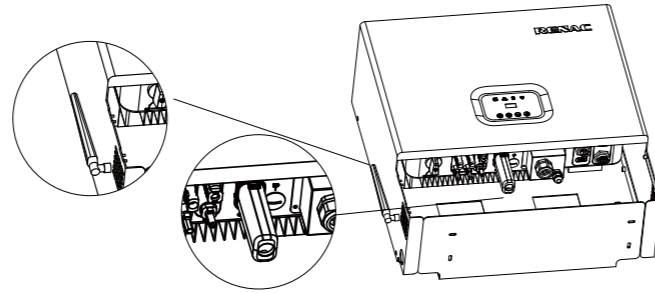

2. ADD Interface

ADD interface PINS definition:

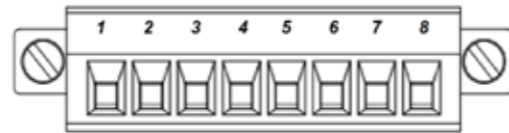

Pin	1	2	3	4	5	6	7	8
Function	METER-485A	METER-485B	GENA	GENB	+5V	SHUTDOWN	Temp	GND

Meter communication: METER_485A & METER_485B—pin1 & pin2
 Relay contact output for generator: GENA & GENB—pin3 & pin4
 Shut down the hybrid inverter: +5V & SHUTDOWN—pin5 & pin6
 Temperature of Lead-acid battery Temp & GND—pin7 and pin8

3. METER port

Meter port PINS definition:

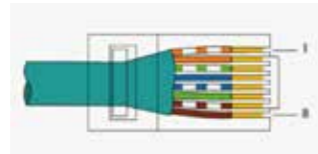

Pin	1	2	3	4	5	6	7	8
Function	METER-485A	METER-485B	NC	NC	NC	NC	NC	NC

The function of meter port same as pin1 & pin2 of ADD interface.

Meter wiring diagram

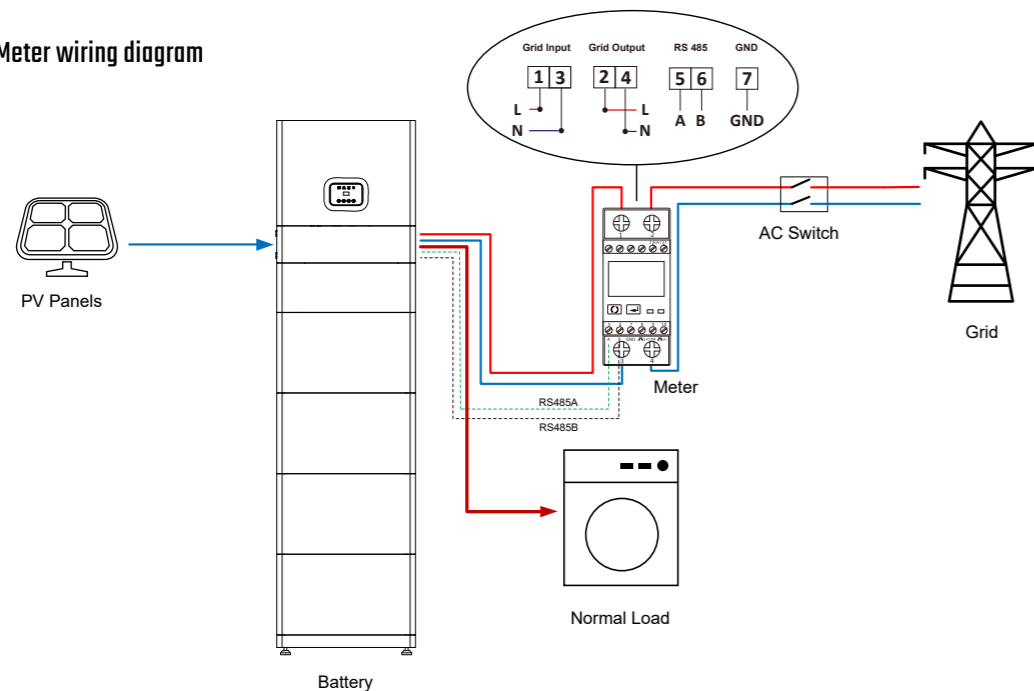

4. DRED

This application meets the requirements of local Australian grid code (AS/NZS 4777.2) which, among specific requirements for connection, calls for compatibility with Demand Response Enabling Devices (DRED). The DRED is under control of a local network operator and allows to put the inverter in one of the Demand Response Modes (DRMs) defined by the standard:

- DRM 0 Operate the disconnection device
- DRM 1 Do not consume power
- DRM 2 Do not consume at more than 50% of rated power
- DRM 3 Do not consume at more than 75% of rated power and source reactive power if capable
- DRM 4 Increase power consumption (subject to constraints from other active DRMs)
- DRM 5 Do not generate power
- DRM 6 Do not generate at more than 50% of rated power
- DRM 7 Do not generate at more than 75% of rated power and sink reactive power if capable.
- DRM 8 Increase power generation (subject to constraints from other active DRMs)

Currently, it is mandatory to respond to DRM0, which allows the network manager to remotely decouple the installation from the distribution network.

DRM PINS definition:

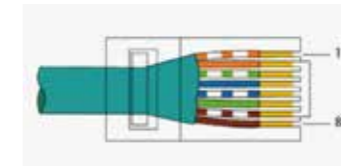

Pin	1	2	3	4	5	6	7	8
Function	DRM1/5	DRM2/6	DRM3/7	DRM4/8	+3.3V	COM/DRM0	GND	HND

5.8 Commisioning

Start inverter after checking all below steps:

- Check that the device is fixed well on the wall.
- Make sure all the PV wiring and the AC wiring are completed.
- Make sure the meter are connected well.
- Make sure the battery is connected correctly.
- Turn on the external AC, DC switch.
- Turn on the DC switch to the 'ON' position.
- Set sysswitch on the screen of the inverter to 'Turn on'

Start inverter:

- Inverter will start automatically when the PV panel generate enough energy or the battery is charged.
- Check the status of LED and LCD screen, first LED should be green and the LCD screen should display the main interface.
- If first LED is not green please check the below:
 - All the connections are right.
 - All the external disconnect switches are closed.
 - The DC switch of the inverter is in the 'ON' positon.
- Enter the setting interface.
- Set the safety standard as page 28; Set the system time as page 27; PV connection mode as page 28; Set the work mode as page 27; Set the communication address as page 28; Set the EPS as page 26; Set WIFI according to the wifi manual;



NOTE!

Please set the inverter if it is the first time to start up. Above steps is for the regular start-up of the inverter. If it is the first time to start up the inverter, you need to start up the inverter.

5.9 Switch on the Battery System

1. Switch on the air switch between the battery and inverter if there is any.
2. Switch on the DC switch on BMC.
3. When the running LED flashes, and the interval time between two flashes is 1 second, push the black start button on BMC.
4. If it is failed to switch on the battery system, check if all the electrical connection is correct.
5. If the electrical connection is correct, but the battery system is still unable to switch on, contact our after-sale service within 48 hours.

5.10 LED state

The Power Battery has a status signal. About the permanently integrated LED in the housing, displayed are the following states:

LED state	Description
Green blinking(1times per second)	BMC DC switch on
Green and red blinking(1times per second)	Push black start button or hybrid inverter awake
Green	Battery system workable
Red	Battery system faults or warning

If faults, warning or events of the battery occur, these are reported on the display of the inverter or can be called up via the Renac SEC.

6. Operation method

6.1 Control panel

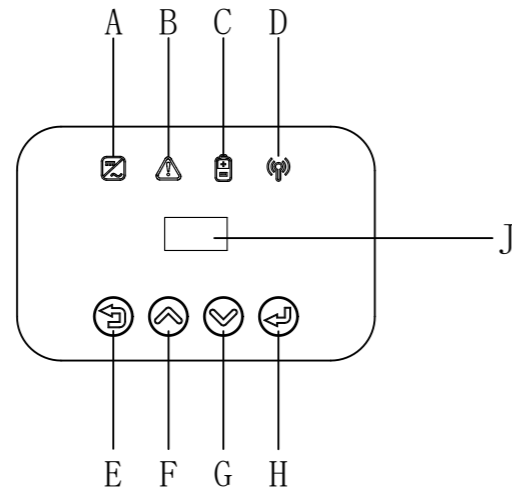

Object	Name	Description
A	Indicator LED	Green: Normal working Status.
B		Red: Fault.
C		Blue: Battery communication status.
D		Yellow: RS485 communication status.
E	Function Button	ESC button: Leave from current interface or function.
F		Up button: Move cursor to upside or increase value.
G		Down button: Move cursor to downside or decrease value.
H		OK button: Confirm the selection.
J	LCD Screen	Display the information of the inverter.

6.2 LCD function Menu structure :

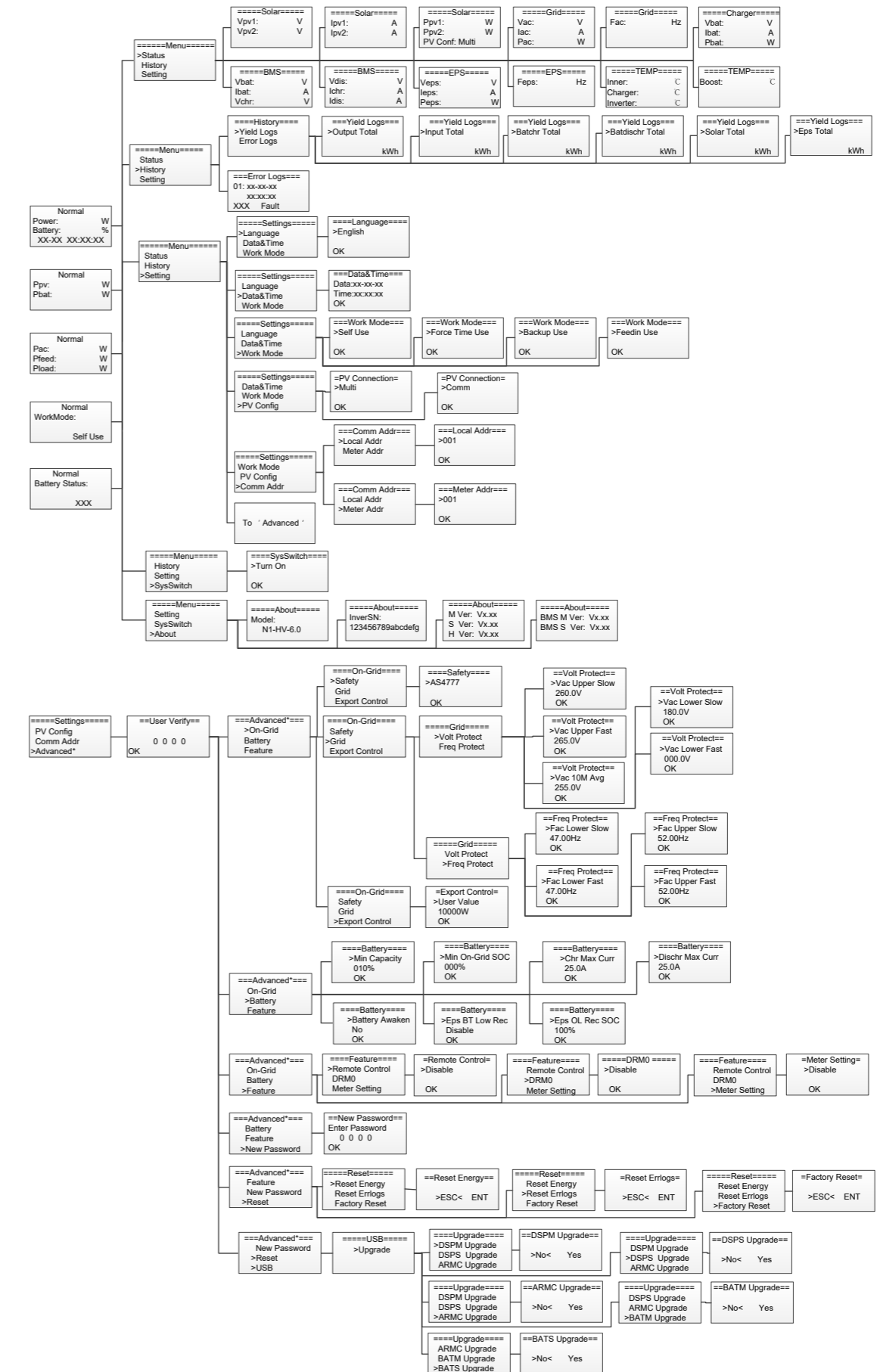

6.3 LCD operation

1. Main screen

The main screen as below. Press up or down for more information.

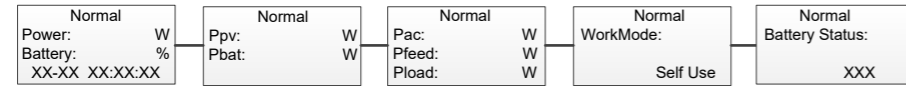

2. Status

Press 'OK' to enter the menu, check grid, solar, battery, EPS and temperature of the inverter. Press up and down to select, press 'ESC' to return to the Menu.

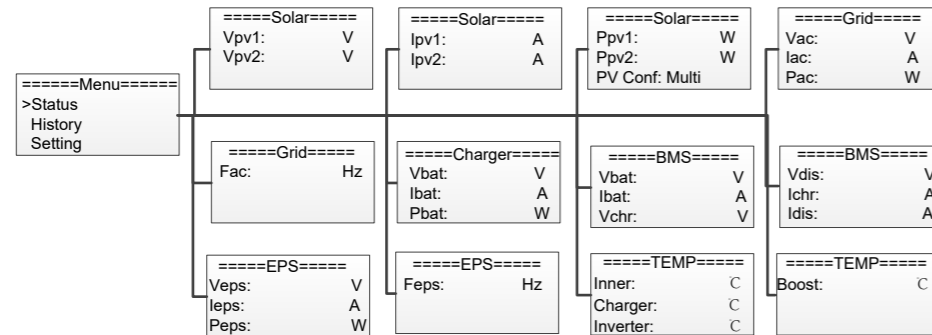

A) Solar

This status shows the real time PV parameters of the system. The input voltage, current and power of each PV input. Press up and down button to review the parameter. Press 'ESC' to return to status.

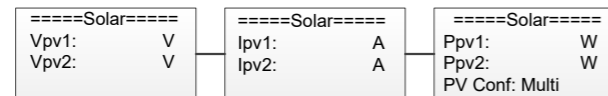

B) Grid

This status shows the real time grid parameters such as voltage, current, output power and frequency. Pac measures the output of the inverter. Press up and down button to review the parameter. Press 'ESC' to return to status.

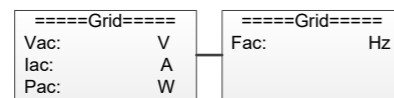

C) Charger

This status shows the charger situation of the system. Include the battery voltage, charge or discharge current. Charge or discharge power. '+' means in charging; '-' means in discharging. Press up and down button to review the parameter. Press 'ESC' to return to Status.

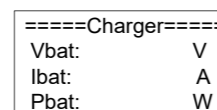

D) BMS

This status shows the battery situation of the system. Include the battery voltage and current, charge and discharge voltage, charge and discharge current. '+' means in charging; '-' means in discharging. Press up and down button to review the parameter. Press 'ESC' to return to Status.

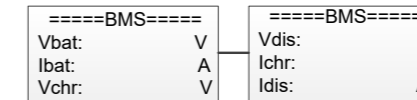

E) EPS

EPS will only have data when the inverter is working in EPS mode, it will show the real time data of the EPS output. As voltage, current, power, frequency. Press up and down button to review the parameter. Press 'ESC' to return to Status.

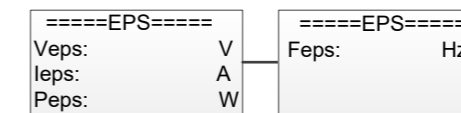

3. History

The history function contains three aspects of the information: inverter yield, battery yield and error log. Press up and down to select, and review the data of system, press 'ESC' to return to the Menu.

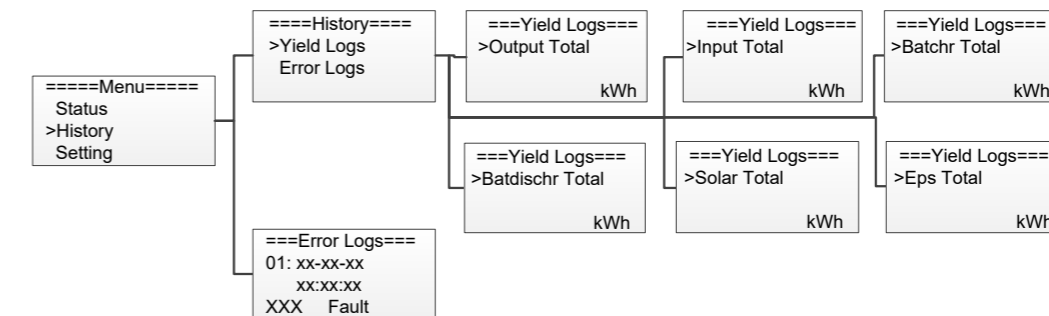

4. Settings

Setting function is used for set the inverter for language, date and time, work mode, PV config, communication address, advanced and so on.

A) Language

Press up or down button to change language. Press 'OK' to confirm.



B) Date Time

Press up or down button to change date and time. Press 'OK' to confirm.

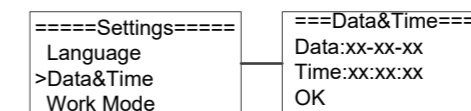

C) Work Mode

Press up or down button to select different work modes. Press 'OK' to confirm.

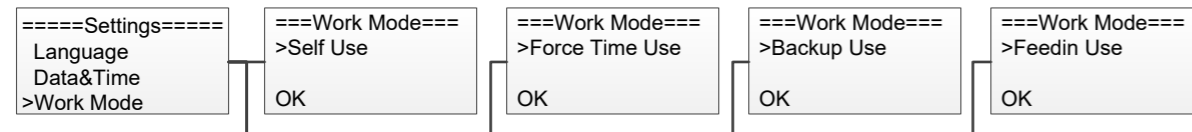

D) PV Connection

This function can set the mode of PV input. There are two modes for selection; Comm and Multi. The 'Comm' mode means single MPP tracking, 2 MPPT working together; 'Multi' means multi-MPP tracking, 2 MPPT work independently. Press up or down button to select and press 'OK' to confirm.

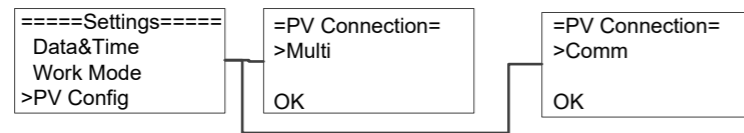

E) Communication Address

Press up or down button to change address of local and meter. Press 'OK' to confirm.

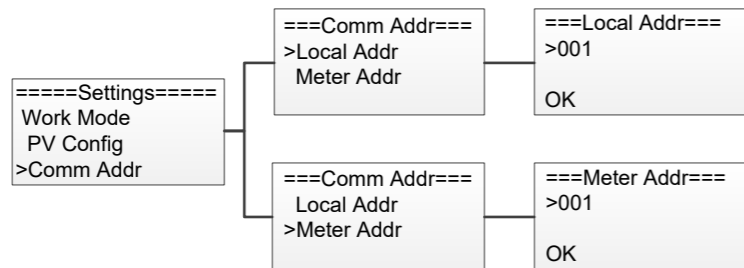

Advanced settings require the original password '0000', Press 'OK' to confirm.

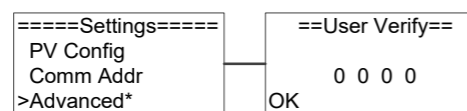

F) Safety

Press up or down button to change the grid code. Press 'OK' to confirm.



G) Grid

Press up or down button to change the value of grid voltage and grid frequency protect. Press 'OK' to confirm.

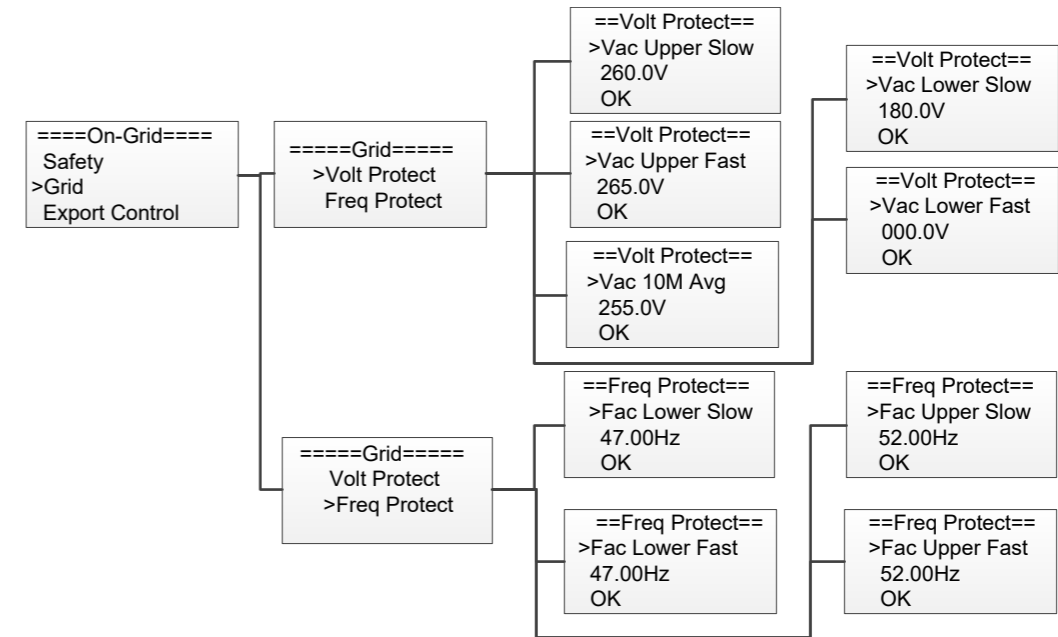

H) Export control

With this function the inverter can control the energy export to the grid. Press up or down button to change the export power. Press 'OK' to confirm..

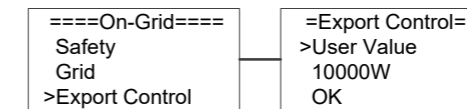

I) Battery

Press up or down button to set the parameters of battery. 'Eps BT Low Rec' means recovery enable switch when battery low capacity in EPS mode, 'Eps OL Rec SOC' means EPS overload due to low capacity for battery, if recovered, min soc. Press 'OK' to confirm.

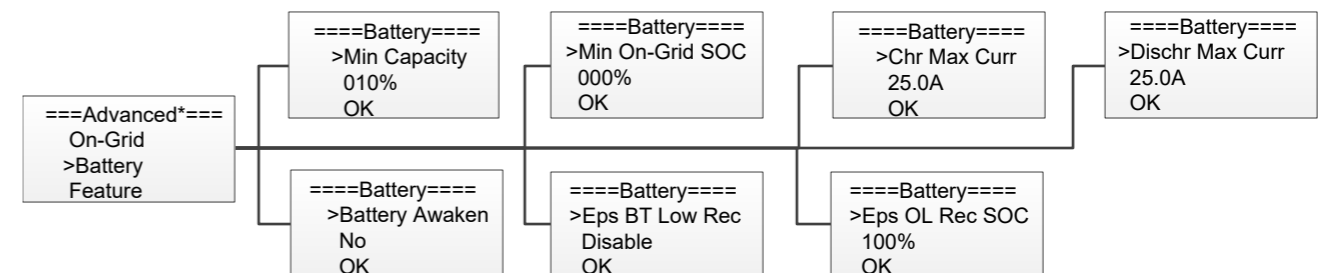

J) Feature

Press up or down button to enable or disable remote control, DRM0, and Meter. Press 'OK' to confirm.

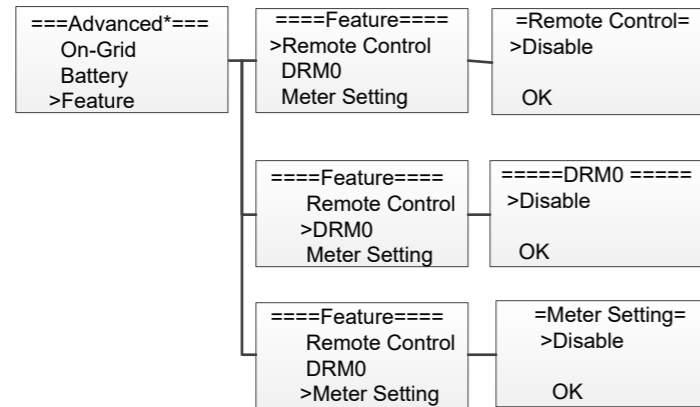

K) New Password

Press up or down button to set new password. Press 'OK' for more than 3 seconds to confirm.

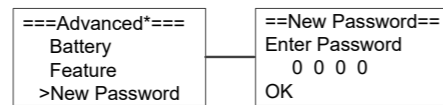

L) Reset

Press up or down button to reset energy, reset errors or factory reset. Press 'OK' to confirm.

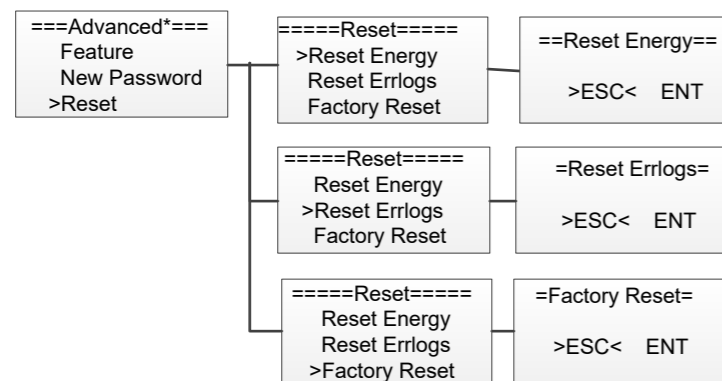

M) USB

Press up or down button to upgrade DSPM, DSPS, ARMC, BATM or BATS. Press 'OK' to confirm.

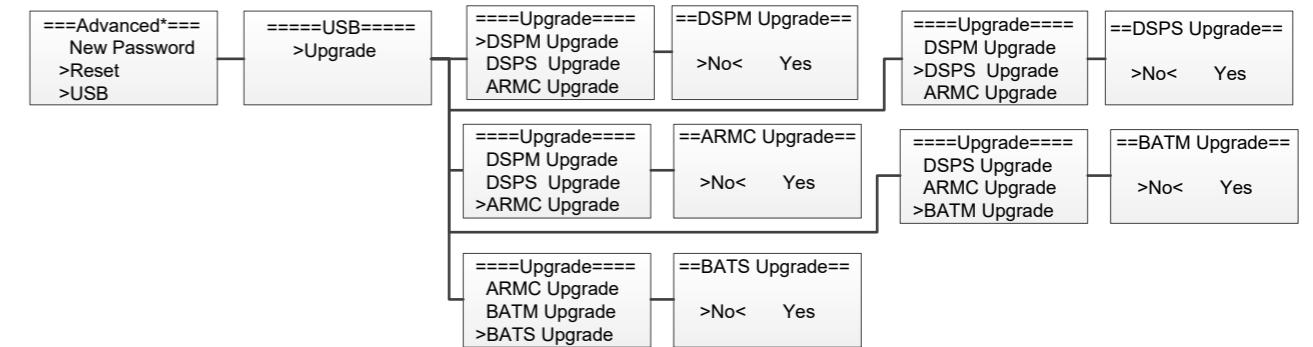

5. System Switch

Press up or down button to turn on or turn off the inverter. Press 'OK' to confirm.



6.4 About

This interface shows the information of the inverter, such as series number and software version.

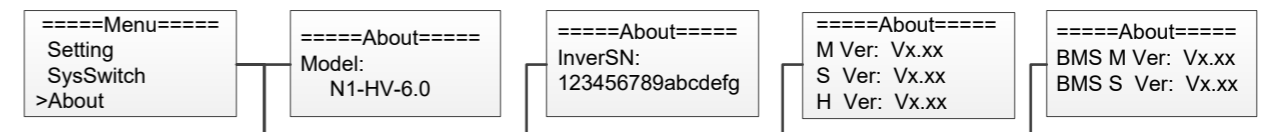

7. Troubleshooting

This section contains information and procedures for solving possible problems with the All in one ESS, and provides you with trouble shooting tips to identify and solve most problems that could occur with the All in one ESS.

This section will help you narrow down the source of any problems you may encounter. Please read the following trouble-shooting steps.

- Check the warning or fault messages on the System Control Panel or Fault codes on the inverter information panel. If a message is displayed, record it before doing anything further.
- Attempt the solution indicated in below table.

HW Protect Fault	Inverter over current or battery over current or PV over current detected by hardware. • Disconnect PV, grid and battery, then reconnect. • Or seek help from us, if not go back to normal state.
Grid Lost Fault	Grid is lost. • System will reconnect if the utility is back to normal. • Or seek help from us, if not go back to normal state.
Grid Volt Fault	Grid voltage out of range. • System will reconnect if the utility is back to normal. • Or seek help from us, if not go back to normal state.
Grid Freq Fault	Grid frequency out of range. • System will reconnect if the utility is back to normal. • Or seek help from us, if not go back to normal state.
PV Volt Fault	PV voltage out of range. • Please check the output voltage of PV panels. • Or seek for help from us.
Bus Volt Fault	Bus voltage out of range detected by hardware. • Disconnect PV, grid and battery, then reconnect. • Or seek help from us, if not go back to normal state.
Bat Volt Fault	Battery voltage fault. • Check if the battery input voltage is within the normal range. • Or seek help from us.
Vgrid 10M Fault	The grid voltage is out of range for the last 10 Minutes. • System will reconnect if the utility is back to normal. • Or seek help from us, if not go back to normal state.
DCI OCP Fault	DC component is out of limit in output current. • Disconnect PV, grid and battery, then reconnect. • Or seek help from us, if not go back to normal state.
DCV OVP Fault	DC component is out of limit in output voltage. • Disconnect PV, grid and battery, then reconnect. • Or seek help from us, if not go back to normal state.
SW OCP Fault	Output current high detected by software. • Disconnect PV, grid and battery, then reconnect. • Or seek help from us, if not go back to normal state.
RC OCP Fault	The residual current is high. • Please check if the insulation of electric wires is damaged. • Wait for a while to check if back to normal. • Or seek for help from us.
Iso Check Fault	The isolation is failed. • Please check if the insulation of electric wires is damaged. • Wait for a while to check if back to normal. • Or seek for help from us.
Temp Over Fault	The inverter temperature is high. • Please check if the environment temperature. • Wait for a while to check if back to normal. • Or seek for help from us.
BatConDir Fault	The battery connection is reversed. • Check if the positive pole and negative pole of battery are correctly connected. • Or seek help from us.

AD Sample Fault	The sample value between master and slave is not consistent. • Disconnect PV, grid and battery, then reconnect. • Or seek help from us, if not go back to normal state.
EPS Over Load	Over load in off grid mode. • Please check if the eps load power exceeds the limit. • Or seek for help from us.
Over Load Fault	Over load in on grid mode. • Please check if the load power exceeds the limit. • Or seek for help from us.
PV Cnf Fault	PV Connection Setting Fault • Resetting the PV connection. • Or seek help from us, if cannot go back to normal state.
Bat Low Fault	The battery power is low. • Wait the battery to be recharged. • Or seek for help from us.
ByPassRelayFault	By pass relay fault • Disconnect PV, grid and battery, then reconnect. • Or seek help from us, if not go back to normal state.
SPI CommFault	The communication between master and slave fault • Disconnect solar power PV+ , PV- and battery, reconnect them. • Or seek help from us, if cannot go back to normal state.
BMS_Lost	The communication between BMS and Inverter is interrupted. • Check if the communication cable between BMS and Inverter is correctly and well connected.
Inter Fan Fault	Fan Device Fault • Disconnect solar power PV+ , PV- and battery, reconnect them. • Check if the fan is stopped by dust or other foreign. • Or seek help from us, if cannot go back to normal state.
AC HCT Fault	AC Current Sensor Fault • Disconnect solar power PV+ , PV- and battery, reconnect them. • Or seek help from us, if cannot go back to normal state.
Inv EEPROM Fault	The master eeprom is fault. • Disconnect PV, grid and battery, then reconnect. • Or seek help from us, if not go back to normal state.
GFCI HW Fault	The residual current circuit is fault. • Please check if the insulation of electric wires is damaged. • Wait for a while to check if back to normal. • Or seek for help from us.
EPS Relay Fault	The EPS relay always keep open. • Disconnect PV, grid and battery, then reconnect. • Or seek help from us, if not go back to normal state.
Grid Relay Fault	The grid relay always keep close. • Disconnect PV, grid and battery, then reconnect. • Or seek help from us, if not go back to normal state.
Other Dev Fault	Other device fault. • Turn off the PV, battery and grid , reconnect them. • Or seek for help from us if cannot back to normal.

Mgr EEPROM Fault	The manager eeprom is fault. • Disconnect PV, grid and battery, then reconnect. • Or seek help from us, if not go back to normal state.
Meter Lost Fault	The communication between meter and Inverter is interrupted. • Check if the communication cable between meter and Inverter is correctly and well connected.
Dsp Lost Fault	SCI communication fault • Disconnect solar power PV+ , PV- and battery, reconnect them. • Or seek help from us, if cannot go back to normal state.
BMS Volt Fault	Battery voltage sensor error • Wait for 5 minutes,, check again. • Or seek help from us, if not go back to normal state.
BMS Tepr Fault	Battery temperature sensor error • Wait for 5 minutes,, check again. • Or seek help from us, if not go back to normal state.
BMS IN_COM Fault	BMS internal communication fault. • Disconnect battery, check wiring between inverter and battery , battery internal wiring then reconnect. • Or seek help from us, if not go back to normal state.
BMS Dcov Fault	Battery input over voltage error • Wait for 5 minutes,, check again. • Or seek help from us, if not go back to normal state.
BMS RV Fault	Battery input transposition error • Wait for 5 minutes,, check again. • Or seek help from us, if not go back to normal state.
BMS Relay Fault	The battery relay is fault. • Disconnect battery, then reconnect. • Or seek help from us, if not go back to normal state.
BMS Cell Fault	Battery cell error • Wait for 5 minutes,, check again. • Or seek help from us, if not go back to normal state.
BMS Other Fault	Battery other error • Wait for 5 minutes,, check again. • Or seek help from us, if not go back to normal state.
BMS Protect OV	Battery over voltage protect • Wait for 5 minutes,, check again. • Or seek help from us, if not go back to normal state.
BMS Protect LV	Battery under voltage protect • Wait for 5 minutes,, check again. • Or seek help from us, if not go back to normal state.
BMS Protect ChrOC	Battery over current charging protect • Wait for 5 minutes,, check again. • Or seek help from us, if not go back to normal state.

BMS Protect DischargeOC	Battery over current discharging protect • Wait for 5 minutes,, check again. • Or seek help from us, if not go back to normal state.
BMS Protect TemHigh	Battery temperature is high • Wait for 5 minutes,, check again. • Or seek help from us, if not go back to normal state.
BMS Protect TemLow	Battery temperature is low • Wait for 5 minutes,, check again. • Or seek help from us, if not go back to normal state.

Remark

If your inverter's information panel is not displaying a Fault light, check the following list to make sure that the present state of the installation allows proper operation of the unit.

- Is the inverter located in a clean, dry, and adequately ventilated place?
- Have the DC input breakers been opened?
- Are the cables adequately sized and short enough?
- Are the input and output connections and wiring in good condition?
- Are the configurations settings correct for your particular installation?
- Are the display panel and the communications cable properly connected and undamaged?

Contact Renac Power Customer Service for further assistance. Please be prepared to describe details of your system installation and provide the model and serial number of the unit.

8. Decommissioning

8.1 Dementling the inverter

- Disconnect the inverter from DC input and AC output.
- Disconnect battery wiring.
- Wait for 5 minutes for de-energizing.
- Disconnect communication and optional connection wiring.
- Remove the inverter from the bracket.

8.2 Packaging

If possible, please pack the inverter with the original packaging.

If it is no longer available, you can also use an equivalent carton that meets the following requirements.

- Suitable for loads more than 25kg.
- With handle.
- Can be fully closed.

8.3 Storage

Store the inverter in dry place where ambient temperatures are always between -20 °C - +60 °C.

8.4 Disposal

When the inverter or other related components need to be disposed. Have it carried out according to local waste handling regulations. Please be sure to deliver wasted inverters and packing materials to certain site, where can assist relevant department to dispose and recycle.

SMART ENERGY FOR BETTER LIFE

RENAC

RENAC POWER TECHNOLOGY CO., LTD.

Block C-12, No. 20 Datong Road, Comprehensive Bonded Zone, Suzhou Hi-Tech District, Suzhou, China

Tel: +86-0512-66677278

info@renacpower.com

www.renacpower.com