N3-HV Series



User Manual

N3-HV-5.0

N3-HV-6.0

N3-HV-8.0

N3-HV-10.0

RENAC

Content

1. About This Manual	3
1.1 Applicability	3
1.2 Target group	3
1.3 Symbols used	3
2. Safety	3
2.1 General Safety	3
2.2 Important safety instructions	3
2.3 Explanation of symbols	5
3. Introduction	5
3.1 Basic features	5
3.2 Work modes	6
3.3 Terminals	8
3.4 Dimension	9
4. Technical data	9
5. Installation	11
5.1 Unpacking	11
5.2 Check for transport damage	13
5.3 Installation precaution	13
5.4 Available space	13
5.5 Preparation	13
5.6 Installation steps	15
5.7 Electrical Wiring Connection	16
5.7.1 PV Wiring Connection	17
5.7.2 Battery Connection	18
5.7.3 AC Output Connection	20
5.7.4 Earth Connection	21
5.7.5 Communication connection	22
5.8 Inverter manipulation	24
6. Operation method	25
6.1 Control panel	25
6.2 LCD function	26
6.3 LCD operation	27
7. Troubleshooting	33
8. Decommissioning	37
8.1 Dementling the inverter	37
8.2 Packaging	37
8.3 Storage	37
8.4 Disposal	37

Notice

This manual contains important safety instructions that must be followed during installation and maintenance of the equipment.

Save the manual!

IMPORTANT TO READ CAREFULLY AND KEEP FOR POSSIBLE CONSULTATIONS

Copyright Declaration

All rights to the content of this manual are owned by RENAC Power Technology Co., Ltd. (hereinafter called as 'RENAC Power'). Any corporation or individual should not plagiarize, partially copy or fully copy it, and no reproduction or distribution of it in any form or by any means without prior written permission from RENAC Power.

RENAC Power reserves the right of final interpretation. This manual may be updated according to user's or customer's feedback. The information in this manual is subject to change without notice. Please check our website at <http://www.renacpower.com> for latest version.

1. About This Manual

1.1 Applicability

Please read the product manual carefully before installation, operation or maintenance. This manual contains important safety instructions and installation instructions that must be followed during installation and maintenance of the equipment.





N3-HV-5.0 N3-HV-6.0 N3-HV-8.0 N3-HV-10.0

1.2 Target group

This manual is intended for qualified electrical technical personnel who are responsible for hybrid inverter installation and commissioning in the energy storage system.

1.3 Symbols used

The following types of safety instructions and general information appear in this document as described below:

	DANGER! 'Danger' indicates a hazard with a high level of risk that, if not avoided, will result in death or serious injury.
	WARNING! 'Warning' indicates a hazard with a medium level of risk that, if not avoided, will result in death or serious injury.
	CAUTION! 'Caution' indicates a hazard with a low level of risk that, if not avoided, could result in minor or moderate injury.
NOTICE	NOTICE! 'Notice' indicates a situation that, if not avoided, could result in equipment or property damage.
	NOTE! 'Note' provides tips that are valuable for the optimal operation of your product.





2. Safety

2.1 General Safety

The hybrid inverter has been designed and tested strictly according to international safety regulations. Read all safety instructions carefully prior to any work and observe them at all times when working on or with the hybrid inverter. Incorrect operation or work may cause:

- ◆ injury or death to the operator or a third party;
- ◆ damage to the inverter or other properties.

2.2 Important safety instructions









	<p>DANGER!</p> <ul style="list-style-type: none"> ◆ PV strings will produce electrical power when exposed to sunlight and can cause a lethal voltage and an electric shock. ◆ Only qualified personnel can perform the wiring of the PV panels. ◆ Do not open the enclosure when the inverter is running. Unauthorized opening will void warranty and warranty claims and in most cases terminate the operating license. ◆ When the enclosure lid is removed, live components can be touched which can result in death or serious injury due to electric shock. ◆ Operating a damaged inverter can lead to hazardous situations that can result in death or serious injuries due to electric shock. ◆ Batteries deliver electric power, resulting in burns or a fire hazard when they are short circuited, or wrongly installed. ◆ Lethal voltages are present at the battery terminals and cables connecting to the inverter. Severe injuries or death may occur if the cables and terminals in the inverter are touched. ◆ PV negative (PV-) and battery negative (BAT-) on inverter side is not grounded as default design. Connecting PV- or BAT- to EARTH are strictly forbidden.
	<p>WARNING!</p> <ul style="list-style-type: none"> ◆ Do not disconnect PV connectors, AC connector or battery connectors while the inverter is running. De-energize from all multiple power sources. Wait 5 minutes for the internal capacitors to discharge. Verify that there is no voltage or current before disconnecting any connectors. Use personal protective equipment, including rubber gloves and protective boots during the installation or maintenance.
	<p>CAUTION!</p> <p>Do not touch any hot parts (such as the heat sink) during operation, The temperature of inverter surface might exceed 60 °C during working</p>
<p style="text-align: center;">NOTICE</p>	<p>CAUTION!</p> <ul style="list-style-type: none"> ◆ Electrical installation and maintenance must be carried out by competent electricians according to local regulations. ◆ Do not open inverter cover or change any components without RENAC Power's authorization, otherwise the warranty commitment for the inverter will be invalid. ◆ Usage and operation of the inverter must follow instructions in this user manual, otherwise the protection design might be useless and warranty for the inverter will be invalid.
	<p>NOTE!</p> <ul style="list-style-type: none"> ◆ Electrical installation and maintenance must be carried out by competent electricians according to local regulations. The inverter built-in RCMU will exclude possibility of DC residual current to 6mA, thus in the system an external RCD (type A) can be used(≥30mA).

Anti-Islanding Effect

Islanding effect is a special phenomenon that grid-connected PV system still supply power to the nearby grid when the voltage loss is happened in the power system. It is dangerous for maintenance personnel and the public. N3-HV series inverter provide Active Frequency Drift(AFD) to prevent islanding effect.

2.3 Explanation of symbols

This section gives an explanation of all the symbols shown on the type label. Symbols on the Type Label

Symbol	Explanation
	CE mark. The inverter complies with the requirements of the applicable CE guidelines.
	Beware of hot surface. The inverter can become hot during operation. Avoid contact during operation.
	Danger of high voltages. Danger to life due to high voltages in the inverter!
	Danger. Risk of electric shock!
	The inverter cannot be disposed of together with the household waste. Disposal information can be found in the enclosed documentation.
	Don't work on this inverter until it is isolated from battery, mains and on-site PV generation suppliers.
	Danger to life due to high voltage. There is residual voltage in the inverter which needs 5 min to discharge. Wait 5 min before you open the upper lid or the DC lid.
	Please read this manual before installation

3.1 Basic features

The N3-HV Series hybrid inverters apply to PV energy storage system with PV modules, battery, loads and grid. The energy produced by PV system shall be used to optimize self-consumption, excess power charge battery and the rest power could be fed into the grid. Battery shall be discharged to support loads when PV power is insufficient to meet self-consumption. If both PV power and battery power is insufficient, the system will take power from grid to support loads.

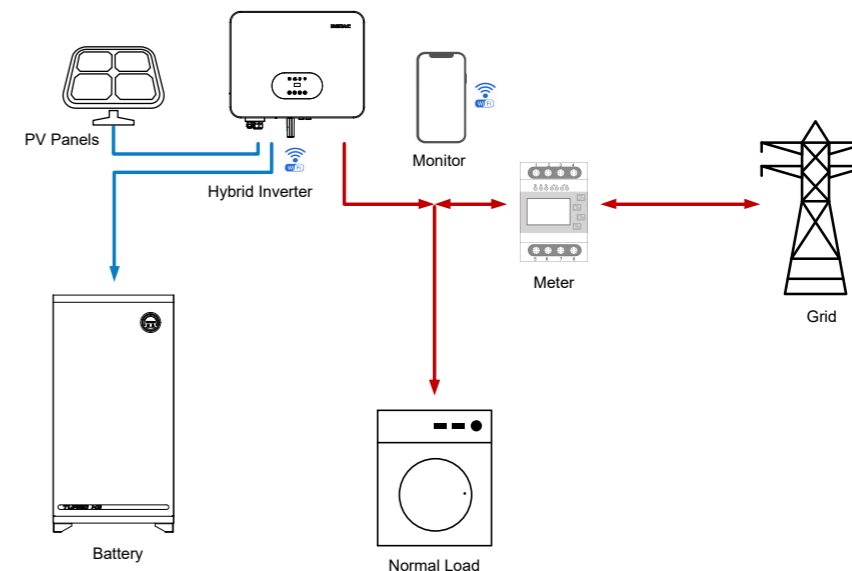

3.2 Work modes

The N3-HV Series hybrid inverter has the following work modes based on your configuration and layout conditions.

Work mode: Self-use

Priority: load>battery>grid

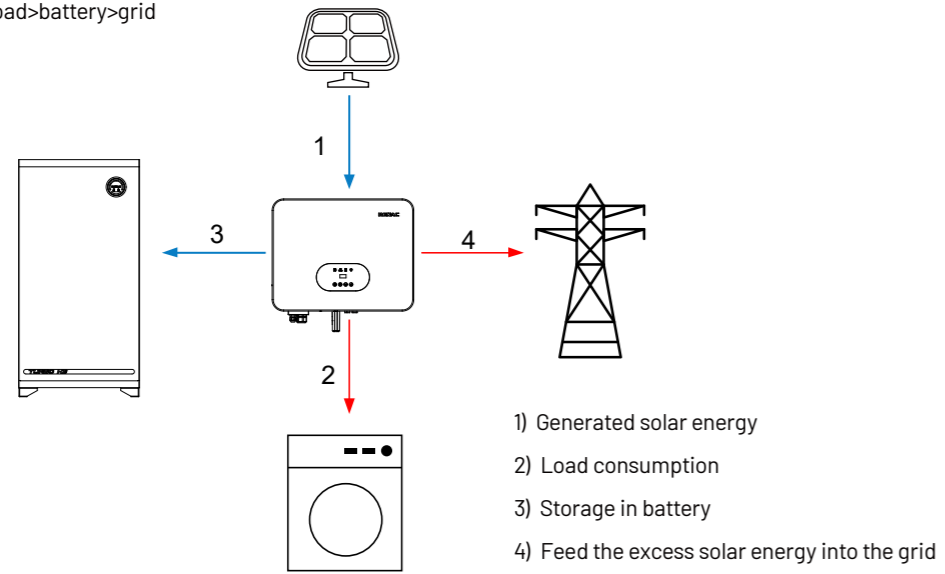

Self-consumption of PV renewable energy is the highest priority. The PV excess is used to charge the batteries, then fed back into the grid.

Work mode: Feed in Pirority

Priority:load>grid>battery

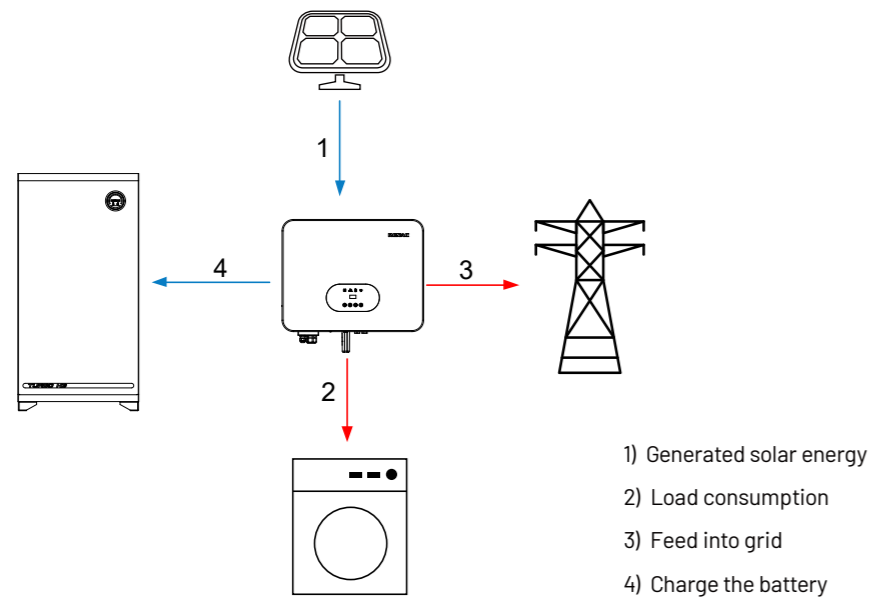

This mode applies the area that has high feed-in tariff and export control. The PV generated power will be used to supply the loads firstly, then feed into the grid. The excess power will charge the battery.

Work mode: Force time use

Priority: battery>load>grid (when charging)

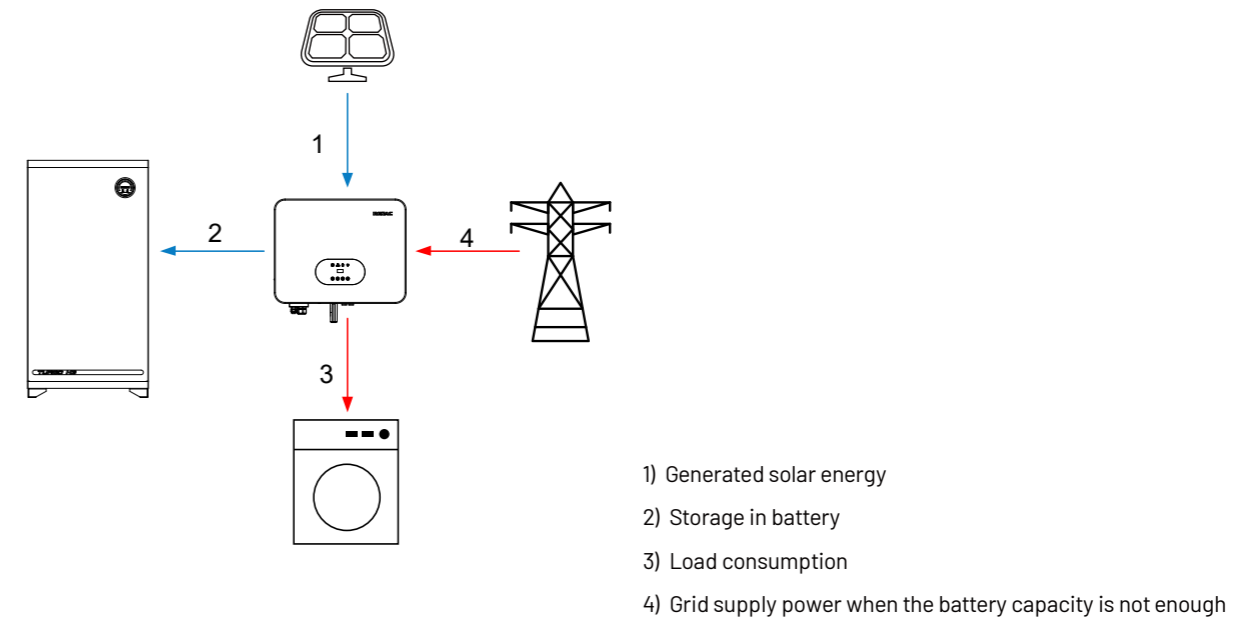

Priority: load>battery>grid (when discharging)

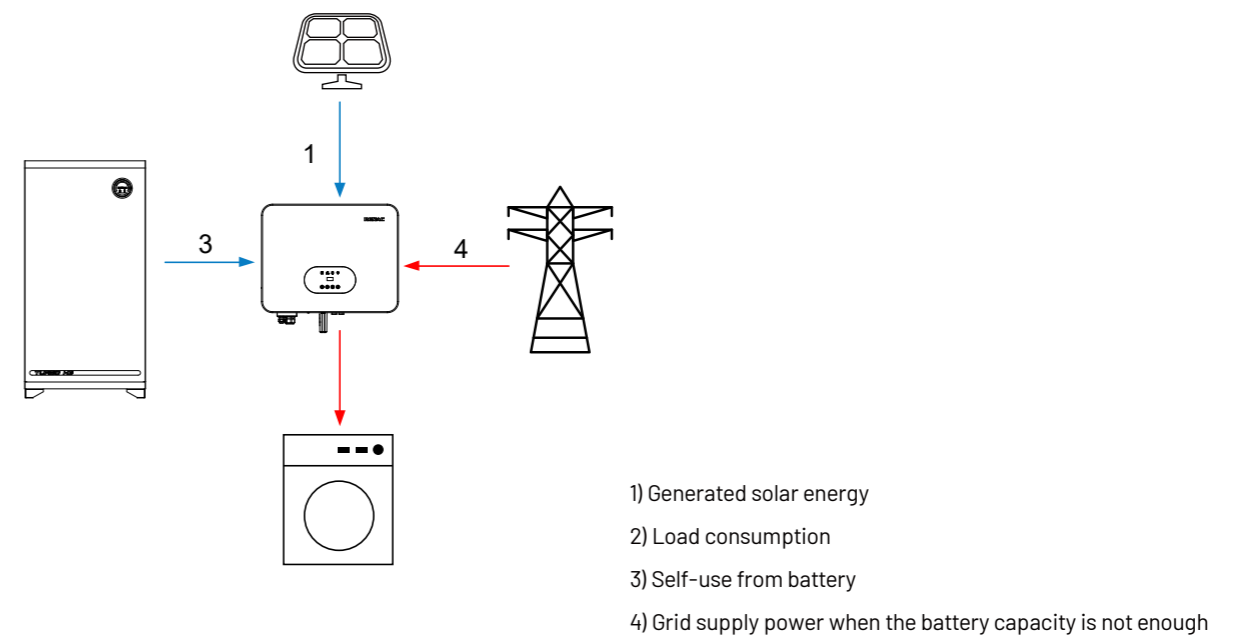

This mode applies the area that has electricity price between peak and valley. User can use off-peak electricity to charge the battery. The charging and discharging time can be set flexibly, and it also allows choosing whether charge from the grid or not.

Work mode: Back up mode

Priority: battery>load>grid

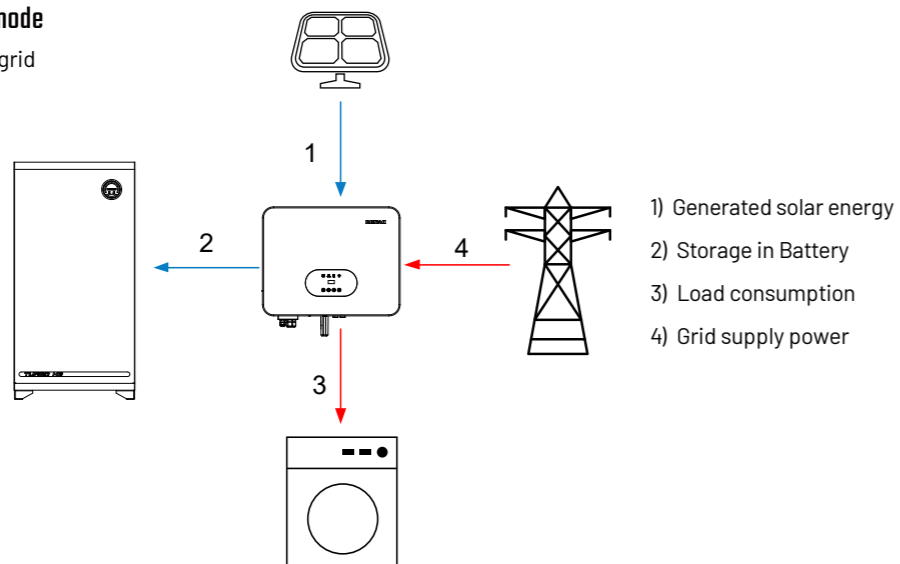

This mode applies the area that has frequent power outages. And this mode ensures the battery will has enough energy to supply during a grid outage. The back up load could be supported by PV and battery in the event of a blackout.



WARNING!
 Make sure the load powering rating in within the EPS's output rating. Or the inverter will shut down with an 'over load' warning. When an 'over load' is appeared, adjust the load power make sure it is with the range of the EPS output, and turn the inverter on. For the nonlinear load, please pay attention to the inrush power make sure it is within the range of the EPS output.

3.3 Product overview

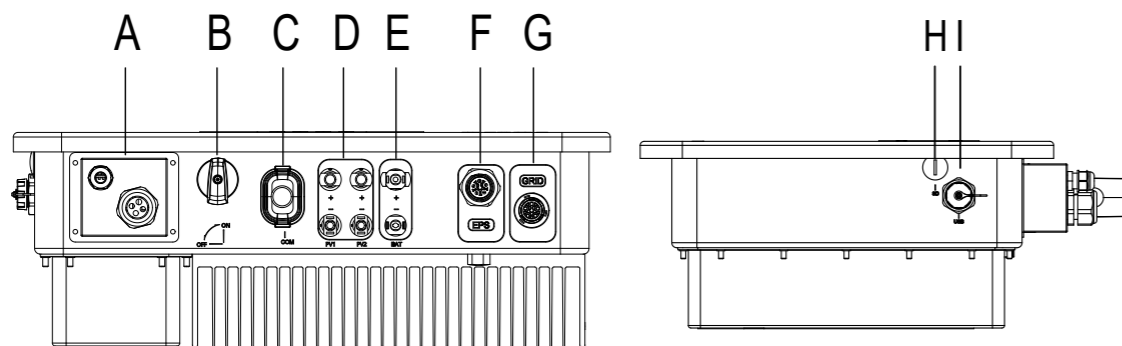

Object	Description	Object	Description
A	Communication port	F	EPS port
B	DC switch	G	Grid port
C	WiFi or GPRS port	H	SD port
D	PV connectors	I	USB port
E	Battery connectors		

3.4 Dimension

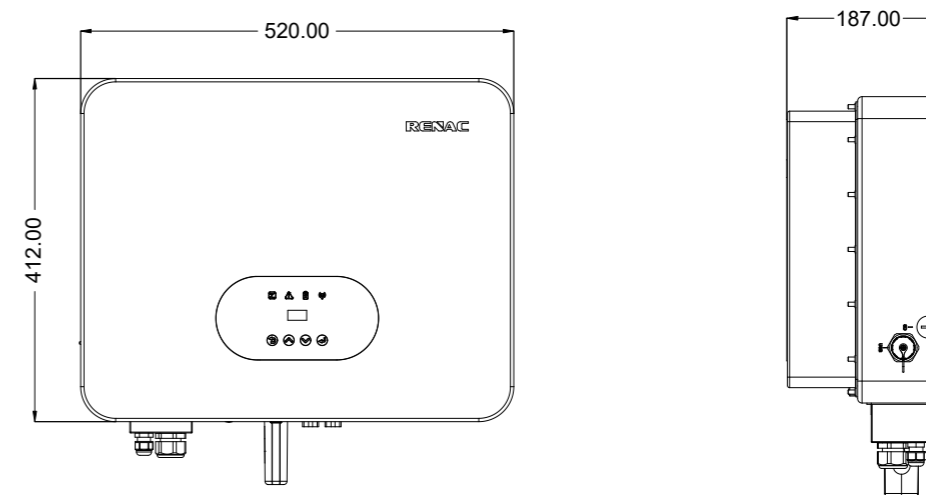

4 Technical data

Model	N3-HV-5.0	N3-HV-6.0	N3-HV-8.0	N3-HV-10.0
PV Input Data				
Max. Recommended PV Power (W)	7500	9000	12000	15000
Max. DC Input Voltage (V)	1000			
MPPT Voltage Range (V)	160~960			
Rated DC input voltage (V)	600			
Start-up Voltage	160			
No. of MPP Trackers	2			
No. of Input Strings per Tracker	1			
Max. DC Input Current (A)	18 / 18			
Max. Short Circuit Current(A)	23/23			
Backfeed Current to Array(A)	0			
DC Switch	Integrated			
AC Output Data				
Rated AC Power (W)	5000	6000	8000	10000
Maximum continuous AC Current (A)	7.6	9.1	12.2	15.2
Rated AC Voltage / Range (V)	3 / N / PE, 220 / 380, 230 / 400			
Grid Frequency / Range (Hz)	50 / 60; ± 5			
Adjustable Power Factor [cosφ]	0.8 leading ~ 0.8 lagging			
Output THDi (@Rated Output) (%)	< 3			

AC Input Data				
Rated AC Power (W)	10000	12000	16000	20000
Maximum continuous AC Current(A)	15.2	18.2	24.3	30.4
Rated AC Voltage / Range (V)	3 / N / PE, 220 / 380, 230 / 400			
Grid Frequency / Range (Hz)	50 / 60			
AC Inrush Current (A)	32			
Maximum Output Overcurrent Protection	40			
AC Maximum output fault current (A)	73			
Output DC(Battery)				
Battery Type	Lithium			
Battery Voltage Range (V)	160 ~ 700			
Max. Charging / Discharging Current (A)	30			
Communication Interface	CAN			
EPS Output (With Battery)				
EPS Rated Power (W)	5000	6000	8000	10000
EPS Rated Voltage (V)	5000	6000	8000	10000
EPS Rated Frequency (Hz)	3 / N / PE, 220 / 380, 230 / 400			
EPS Rated current (A)	50 / 60			
Output THDi (@Rated Output) (%)	7.6	9.1	12.2	15.2
Automatic Switch Time (ms)	< 3%			
Peak Apparent Power (rated).Duration (s)	< 10			
Efficiency				
Max. Efficiency (%)				
Euro Efficiency (%)	98.00%	98.00%	98.00%	98.00%
Max. Battery Discharge Efficiency (%)	97.70%	97.70%	97.70%	97.70%
Protection				
DC Insulation Monitoring	Intergrated			
Input Reverse Polarity Protection	Intergrated			
Anti-island Protection	Intergrated			
Residual Current Monitoring	Intergrated			
Over-heat Protection	Intergrated			
AC Overcurrent Protection	Intergrated			

AC Short-circuit Protection	Intergrated
AC Overvoltage Protection	Intergrated
DC Surge Protection	Type II
AC Surge Protection	Type II
General Data	
Size (Width * Height * Depth mm)	520 * 412 * 186
Weight (kg)	27
User Interface	LED+OLED
Communication	RS485 and USB or Wifi or 4G (Optional)
Operating Temperature Range (°C)	-25 ~ +60
Relative Humidity (%)	0% ~ 100%
Operating Altitude (m)	≤ 4000
Standby Self Consumption (W)	<15
Topology	Transformerless
Pollution degree	II
Protective class	I
OVC categories	DC II / AC III
Environmental categories	Outdoor conditioned
Cooling	Natural
Protection Grades	IP65
Noise (dB)	< 35
Warranty (years)	5
Certifications & Standards	
Grid Regulation	AS 4777,EN 50549,IEC 61727,CEI 0-21, EC 62116,IEC 60068,IEC 61683
Safety Regulation	IEC 62109-1,IEC 62109-2,IEC 62040
EMC	EN 61000-6-2,EN 61000-6-3,EN 61000-4-16,EN 61000-4-18,EN 61000-4-29

5 Installation

5.1 Unpacking

Check the delivery for completeness. Contact your dealer at once if anything is missing.



Object	Quantity	Description
A	1	N3-HV inverter
B	1	Bracket
C	2	Battery Connectors (1* positive, 1*negative)
D	4	PV Connectors (2* positive, 2*negative)
E	4	PV Pin contact (2* positive, 2* negative)
F	1	AC Terminal
G	1	EPS Terminal
H	1	8P Pluggable Terminal Block
I	1	WiFi or GPRS Module(Optional)
J	5	Ethernet RJ45 Connector
K	1	M5 Screw
L	1	Earth Terminal
M	4	Expansion tubes& Expansion screws
N	1	Meter
O	1	User Manual & Quick installation guide
P	1	Quality Certificate

Open the package and pick the product, check that if there is any distortion or impaired during the transportation. Meanwhile, check that if the relating accessories and the materials are here, you can see the accessories list in the table.

The instruction manual is an integral part of the unit and should therefore be read and kept carefully.

It is recommended that the packaging should not be removed until the unit is located in the installation site.

5.2 Check for transport damage

Check if the N3-HV series inverter has some visible external damage, such as cracks in the housing or display please contact with your dealer if you find any damage.

5.3 Installation precaution

The N3-HV series inverter is designed for outdoor installation (IP65)

Make sure the installation site does not fall into one of the following conditions:-Do not install the inverter in direct sunlight.

- Do not install the inverter on flammable construction material.
- Do not install the inverter in areas where highly flammable materials are stored.
- Do not install the inverter in potentially explosive areas.
- Do not install the inverter during periods of precipitation or high humidity (>95%); Moisture trapped within the location may cause corrosion and damage to the electric components.
- Provide adequate ventilation when using batteries, and also read the warning label on the bottom of the inverter.
- Install the inverter in a location that maintains an ambient air temperature that is less than 40°C; That is to maintain a safe internal component temperature; the inverter would reduce power if the ambient air temperature exceeds 40°C.
- The inverter should be installed in a location that is not accessible for children.
- The inverter emits a slight vibrating noise when operating, which is normal and no effect on performance.
- The slope of the wall should be within ±5°.
- The inverter is heavy, ensure the mounting place is strong enough to hold the weight of the inverter.
- If you install the inverter in a cabinet, closet or other small enclosed area, sufficient air circulation must be provided in order to dissipate the heat generated by the unit.

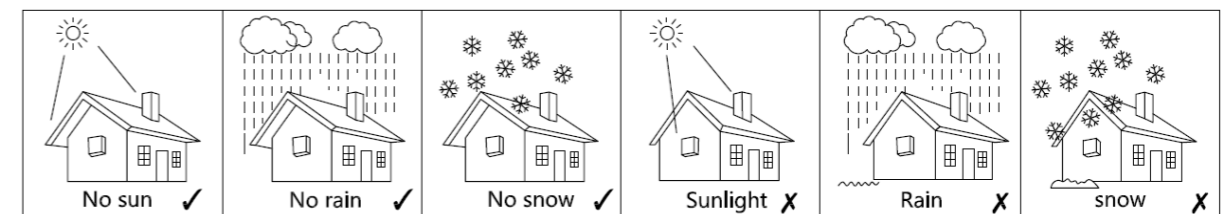

5.4 Available space

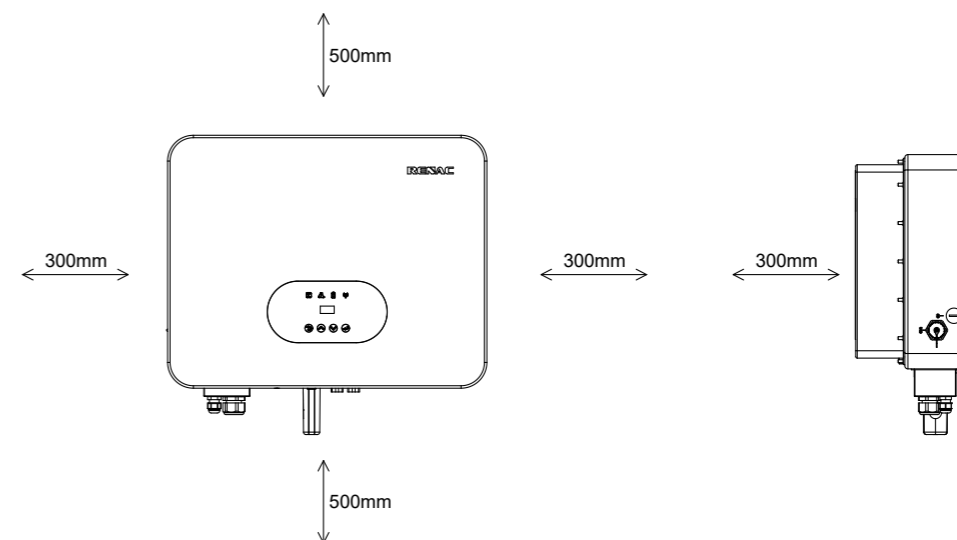

Figure 5-1 inverter space size

5.5 Preparation

No.	Tool	Model	Function
1		Level	Make sure the bracket is properly installed
2		BOSCH HD18-2 Two-Speed Hammer Drill	Drill holes on the wall
3		Hammer	Hanging the bracket
4		KIMO 20V 1/2 Cordless Brushless Impact Wrench Set	Hanging the bracket
5		PV-AZM-410	Stripping plier for PV cable
6		PV-CZM-22100	Crimping plier for PV cable
7		Screwdriver	Wiring
8		RJ45 Crimping Tool	Crimping tool for RJ45 terminal
9		Crimping plier	Crimping Tool For Insulated Electrical Connectors

Lifting and Handling

The unit is heavy. Do not lift it alone.

- During lifting procedures ensure that the unit is firmly secured to avoid the risk of accidental tipping or dropping.
- Parts serving for support or immobilization of unit shall be designed and manufactured so as to minimize the risk of physical injuries and of accidental loosening of fixing.
- Ensure that the method of lifting will not allow the unit to slip from chains and slings or turn-over or slide from lifting devices.

- Transportation must be carried by specialized person (truck operators. Hook-up personal), equipped with the necessary protection equipment (overalls, safe shoes, protective gloves, helmets, goggles)
- Do not walk or stand beneath or in the proximity of the load.
- Avoid sudden movements and jolts when unloading and positioning the unit. Internal handling procedures must be conducted with care. Do not exert leverage on the components of the machine.
- If the unit is not balanced apply ballast. Any protruding parts should not be supported by hand.
- The inverter should be installed so that the operating panel shall be easily accessible- easy access to the electrical power connection point.
- Accessible for maintenance and repair work.
- Parts serving for support or immobilization of unit shall be designed and manufactured so as to minimize the risk of physical injuries and accidental loosening of fixings.
- Loading capacity and hardness of the supporting surface, load rating of mounting bracket should be at least four times the weight of the devices according to IEC62109-1. And supporting characteristics will be impaired by wear, corrosion, material fatigue or ageing, This should be calculated by inspection of the design data of supporting material and consulting construction engineer.

5.6 Installation steps

Step 1: Screw the wall bracket on the wall

- Use the wall bracket as a template to mark the position of the 4 holes.

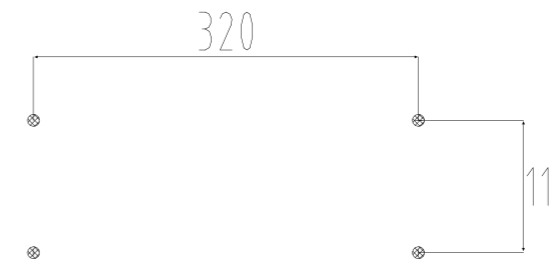

- Drill holes with $\phi 10$ driller carefully, make sure the holes are deep enough (at least 45mm) for install and tight the expansion tubes.
- Install the expansion tubes in the holes, and tight them. Install the wall bracket using the expansion screws in the screw package.

Step2: Hang the N3 HV inverter on the wall bracket.

- Transportation of the inverter needs at least 2 people, each one needs to use the handles at the sides of the inverter.
- Hang the inverter over the bracket, move the inverter close to it, slightly laydown the inverter make sure the 4 mounting bars on the back of the inverter is fixed well with 4 grooves on the bracket.

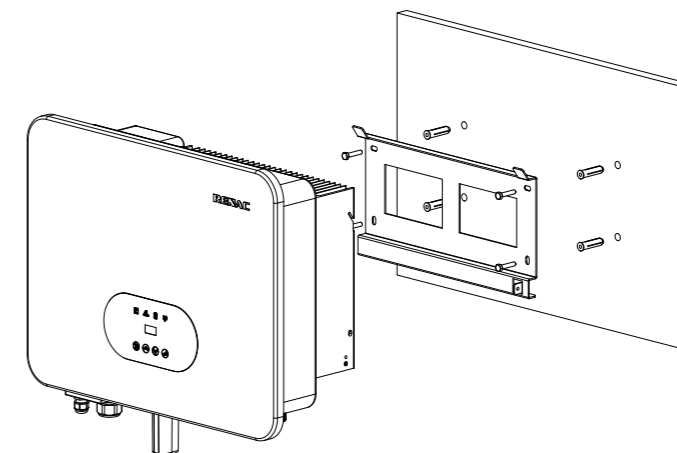

5.7 Electrical Wiring Connection

The overview of the connection terminals of inverter please refer to Figure 3-2, and the wiring connections please refer to Figure 3-1 the PV energy storage system wiring diagram in chapter 3.1.

System Connection Diagrams

Note: This diagram is an example for Australian, South Africa and New Zealand grid system where neutral line can't be switched.

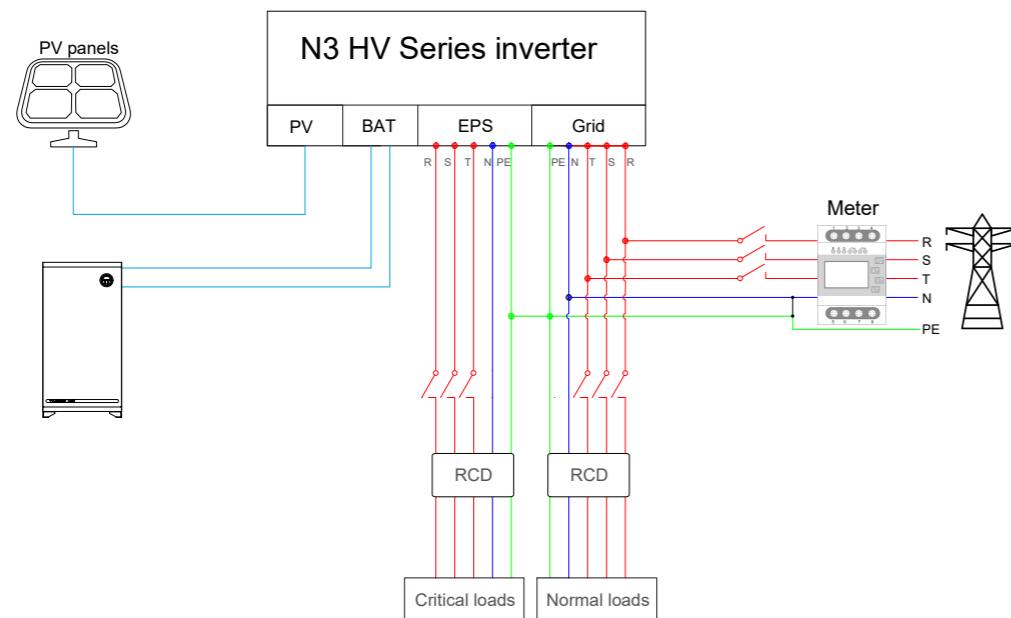

Note: This diagram is an example for grid system without special requirement on electrical wiring connection.

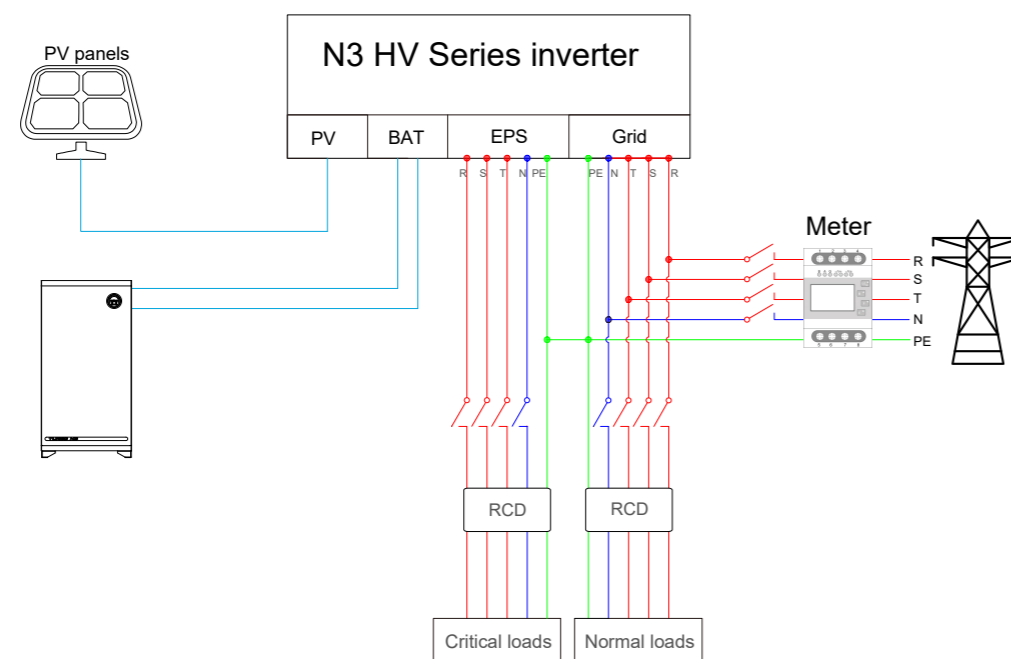

The main steps to connect the N3 HV series system

- PV string connection
- Battery connection
 - Battery power connection
 - Battery communication connection
- AC output connection
- EPS connection
- Earth connection
- Communication connection

5.7.1 PV Wiring Connection

Before connecting PV strings to N3-HV Series hybrid inverter, please make sure requirements are followed as below :

- The total short-circuit current of PV string must not exceed inverter's max DC current .
- Make sure open circuit voltage of PV string is less than 1000V.
- PV strings could not connect to earth/grounding conductor.
- Use the right PV plugs in the accessory box, BAT plugs are similar with PV plugs, please confirm before use it.

Connection Steps:

1. Turn off the DC switch.
2. Prepare 2.5-4mm² PV cable and PV plugs as below.
3. Strip 7mm of the conductor with stripping plier. Use a suitable stripping tool for this (e.g. "PV-AZM-410 ")

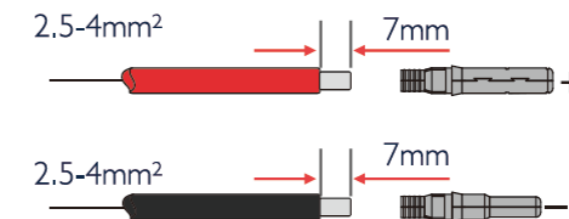

4. Insert striped cable into pin contact and ensure all conductor strands are captured in the pin contact.

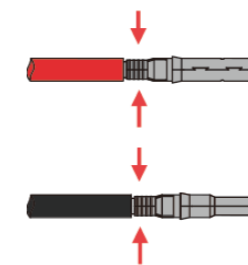

5. Crimp pin contact by using a crimping pliers (PV-CZM-22100). Put the pin contact with striped cable into the corresponding crimping pliers and crimp the contact.
6. Insert pin contact through the cable nut to assemble into back of the male or female plug. When you feel or heard a 'click' the pin contact assembly is seated correctly.

7. Tight the DC connector.
 - a. Slide the cable nut towards the back shell.
 - b. Rotate the cable nut to secure the cable.

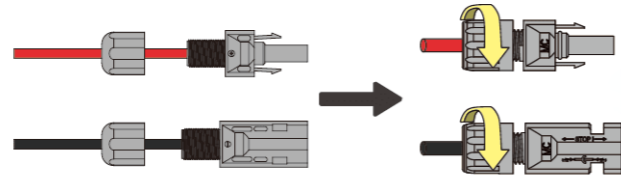

8. After securing the cable tightly, align the 2 half connectors and mate them together by hand until a 'click' is felt or heard.
9. Separate the DC connector
 - a. Use the specified wrench tool.
 - b. When separate the DC+ connector, push the tool down from upside.
 - c. When separate the DC- connector, push tool down from the bottom side.
 - d. Separate the connectors by hands.

5.7.2 Battery Connection

When you want to build a self-use storage system, the high voltage battery is a necessary part. The N3 HV series inverter provides the necessary part of the interfaces to connect the battery.



WARNING!

Make sure you select the correct specification cables for installation. Otherwise the power will make the cable hot or burnt; it could result in death or serious injury.

1. Battery Power Cable Connection

- 1) Prepare the tin-plated cables with a conductor cross section of 4 to 6 mm² (AWG 10).
- 2) Strip 15mm off the conductor. Use a suitable stripping tool for this (e.g. "Knipex Solar 121211").
- 3) Open the spring using a screwdriver ^[1].

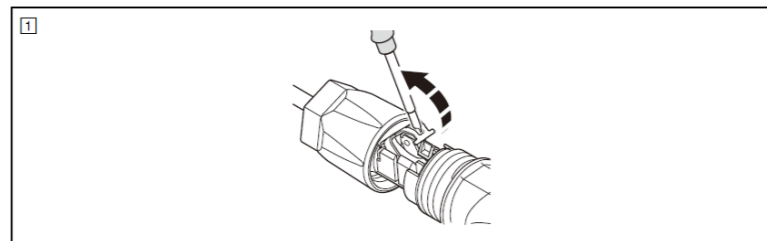

- 4) Carefully insert the stripped wire with twisted litz wires all the way in (^[2], A). The litz wire ends have to be visible in the spring.
- 5) Close the spring. Make sure that the spring is snapped in (^[2], B).

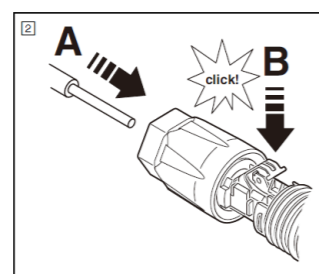

6. Push the insert into the sleeve (^[3], C).
7. Tighten the cable gland to 2 Nm (^[3], D). Use a suitable and calibrated torque wrench, size 15. Use an open-jaw wrench, size 16, to hold the connector in place.

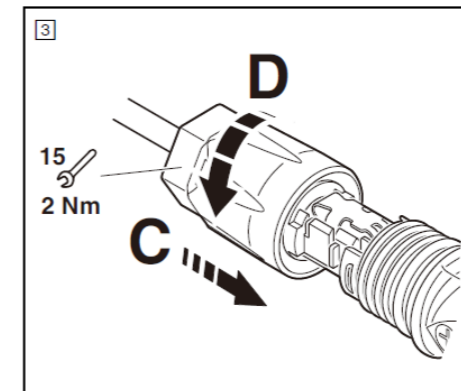

8. Fit the two connectors together until the connection audibly locks into place.
9. Check to make sure the connection is securely locked
10. Separating connectors
 - 1). Insert the screwdriver into one of the four openings (^[4], A).
 - 2). Leave the screwdriver in the opening. Pull the two connectors apart (^[4], B).

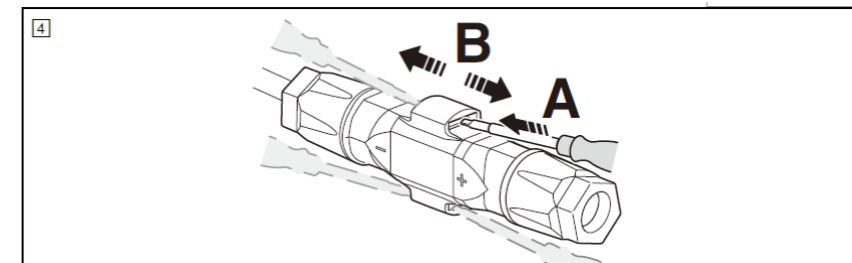

2. Battery Communication Connection

The communication interface between battery and inverter is CAN with a RJ45 connector. The Pins definition is as below.

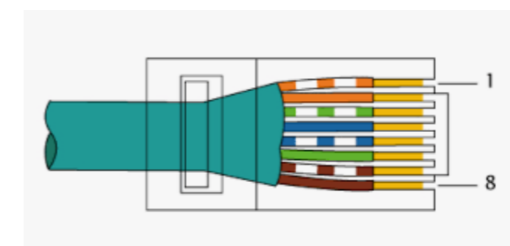

Pin	1	2	3	4	5	6	7	8
Function	NC	NC	NC	CANH	CANL	NC	485A	485B

Overview for all battery connections

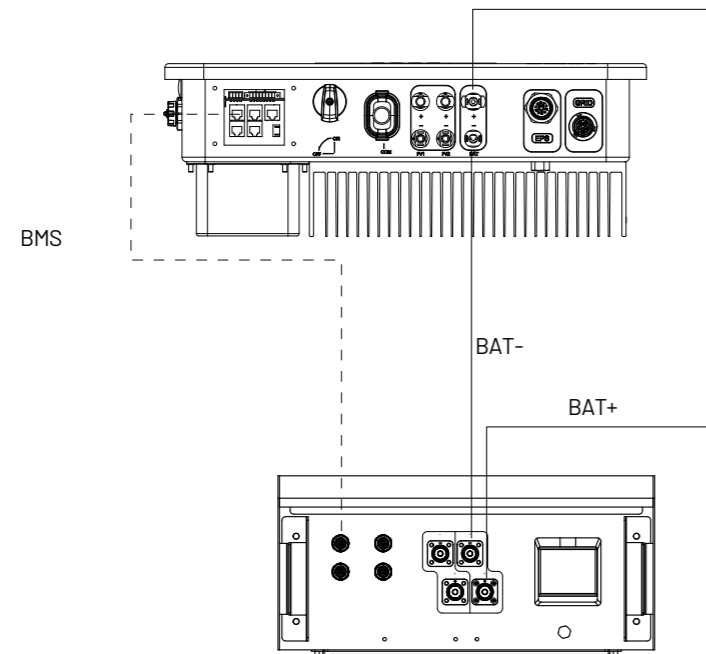

5.7.3 AC Output Connection

N3 HV series inverters have already integrated RCMU (residual current monitoring unit) inside, however if an external RCD is required, a type A RCD with rated residual current of 30mA or higher is recommended.

There are two AC terminals and the assembly steps for both are the same, just need to check one for 'Grid' another for 'EPS'. The AC cable and micro-breaker specification for AC side of N3 HV series inverter as below.

Model	N3-HV-5.0	N3-HV-6.0	N3-HV-8.0	N3-HV-10.0
Cable(Cu)	4mm ²	4mm ²	4mm ²	4-6mm ²
Normal Load-Breaker	10A	16A	16A	20A
Grid-Breaker	20A	32A	32A	40A



WARNING!

Make sure you select the correct specification cables for installation. Otherwise the power will make the cable hot or burnt; it could result in death or serious injury. Don't connect the phase to 'PE' terminal, otherwise the hybrid inverter will not function properly.

Connection Step:

1. Lead the AC cable through the cable gland and the housing.

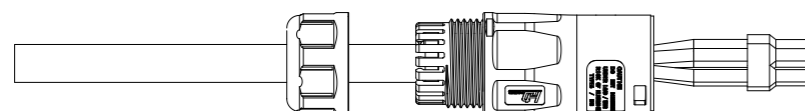

2.Remove the cable jacket by 40 mm, and strip the wire insulation by 8 mm-15 mm.

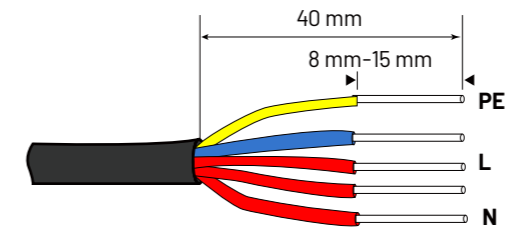

3.Fully insert the conductors to the corresponding terminal and tighten the screws with the torque 0.8 Nm. Pull cables outward to check whether they are firmly installed.

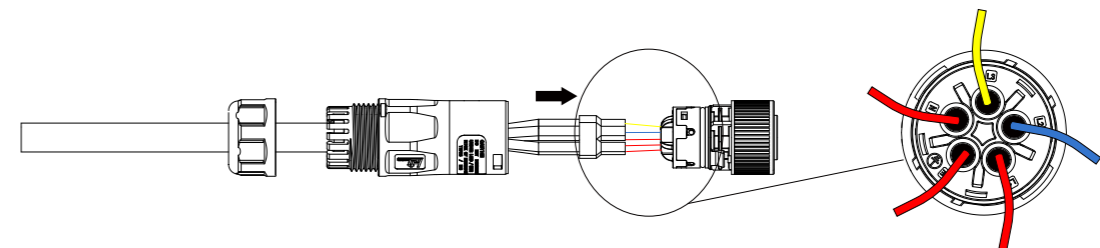

4.Assemble the housing, the terminal block and cable gland (torque 4 Nm-5 Nm). Make sure that the rib of the terminal block and the groove on the housing engage perfectly until a 'Click' is heard or felt.

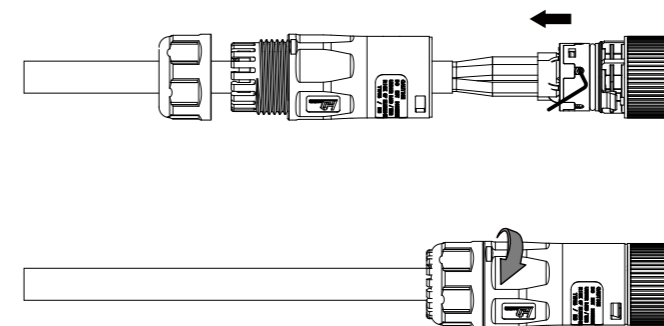

5.7.4 Earth Connection

You can additionally earth the inverter enclosure of a second earthing or equipotential bonding is required locally. This prevents touch current if the original protective conductor fails.

Cable size: 12AWG

Connection step:

- Strip the earthing cable insulation.
- Insert the stripped cable into the ring terminal.
- Clamp the end of the ring terminal.
- Unscrew the screw of the earthing connector.
- Suit the ring terminal on the earthing connector. Suit the gasket on the earthing connector.
- Screw the screw of the earthing connector.

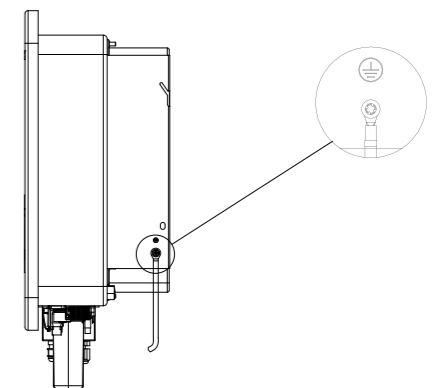

5.7.5 Communication connection

Communication interface

This product has a series communication interfaces besides WIFI or GPRS (optional) , Dry contact and extend port and for human and machine communication, etc., can be delivered to PC or other monitoring equipment via these interfaces.

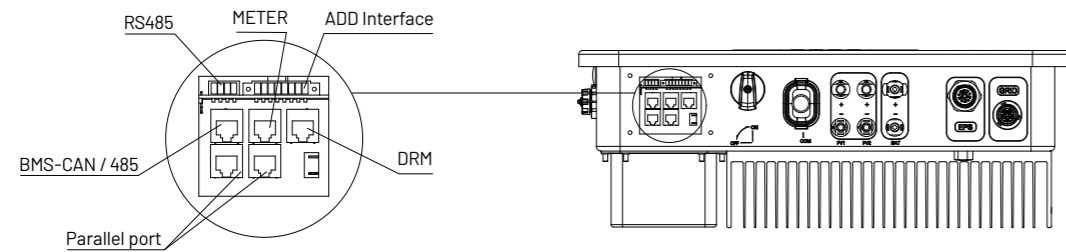

1. WIFI or GPRS

The details please refer to the WIFI or GPRS module user manual.

2. RS485 Interface

RS485 interface PINS definition:

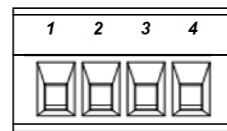

Pin	1	2	3	4
Function	+5V	GND	485A	485B

2. ADD Interface

ADD interface PINS definition:

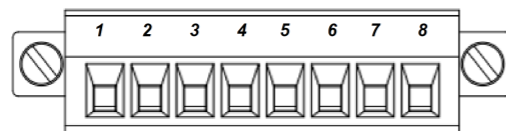

Pin	1	2	3	4	5	6	7	8
Function	METER-485A	METER-485B	GENA	GENB	+5V	SHUTDOWN	Relay	GND

Meter communication: METER_485A & METER_485B—pin1 & pin2
 Relay contact output for generator: GENA & GENB—pin3 & pin4
 Shut down the hybrid inverter: +5V & SHUTDOWN—pin5 & pin6
 EPX box Relay & GND—pin7 and pin8

3. METER port

Meter port PINS definition:

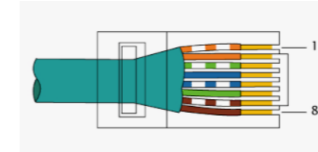

Pin	1	2	3	4	5	6	7	8
Function	METER-485A	METER-485B	NC	NC	NC	NC	NC	NC

The function of meter port same as pin1 & pin2 of ADD interface.

3.1 Meter wiring diagram for Typical Energy Storage System

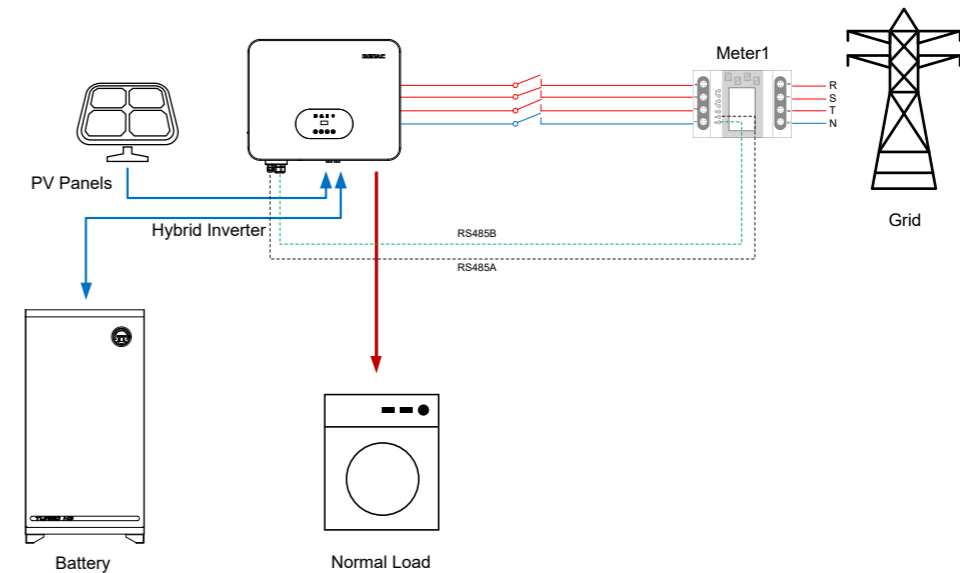

Note:

The default address in the inverter software to recognize the meter is 1,so please confirm if the meter address is 1.Otherwise the meter cant transfer the grid data to the inverter.

3.2 Meter wiring diagram for AC Retrofit System

- 1) Grid-tied solar system has already existed.
- 2) More capacity of power is needed.
- 3) Battery is needed for emergency.
- 4) Extra space for PV panel.

Just add a meter between the grid-connected inverters and N3 HV hybrid inverter.

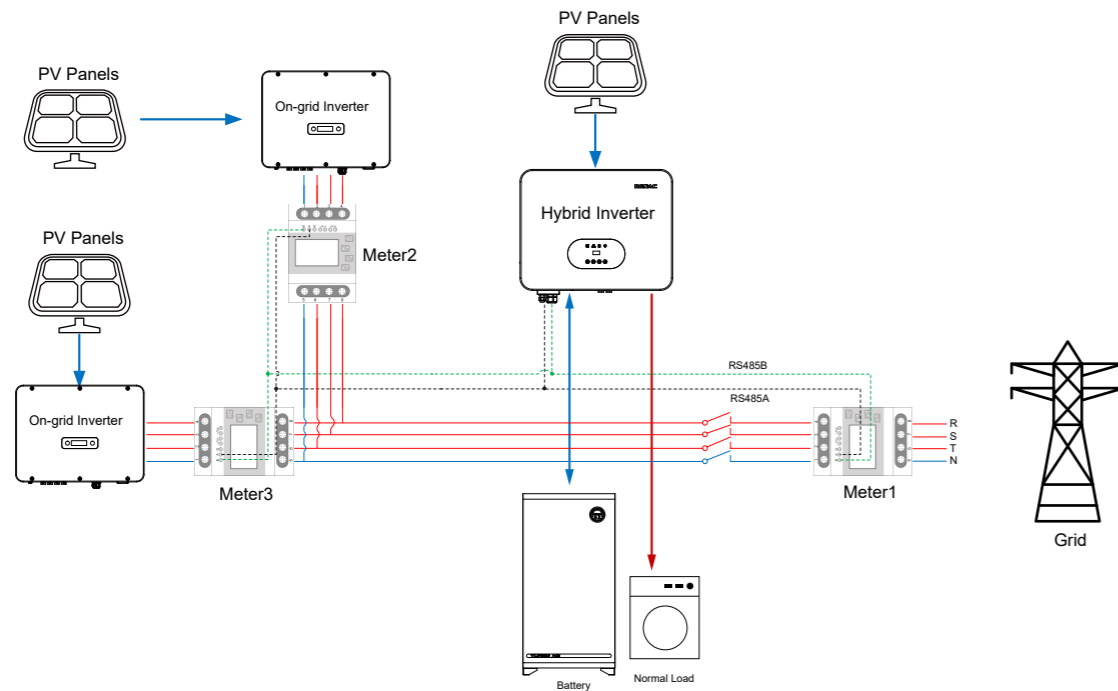

Note:

The default address in the inverter software to recognize the meter1, meter2 and meter3 is 001,002 and 003.(Refer to page 27) So please set the meter1 address to 1, set meter2 address to 2, set meter3 address to 3.

4. DRED

This application meets the requirements of local Australian grid code (AS/NZS 4777.2) which, among specific requirements for connection, calls for compatibility with Demand Response Enabling Devices (DRED). The DRED is under control of a local network operator and allows to put the inverter in one of the Demand Response Modes (DRMs) defined by the standard:

- DRM 0 Operate the disconnection device
- DRM 1 Do not consume power
- DRM 2 Do not consume at more than 50% of rated power
- DRM 3 Do not consume at more than 75% of rated power and source reactive power if capable
- DRM 4 Increase power consumption (subject to constraints from other active DRMs)
- DRM 5 Do not generate power
- DRM 6 Do not generate at more than 50% of rated power
- DRM 7 Do not generate at more than 75% of rated power and sink reactive power if capable.
- DRM 8 Increase power generation (subject to constraints from other active DRMs)

Currently, it is mandatory to respond to DRM0, which allows the network manager to remotely decouple the installation from the distribution network.

DRM PINS definition:

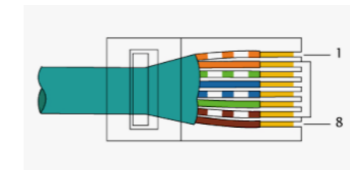

Pin	1	2	3	4	5	6	7	8
Function	DRM1/5	DRM2/6	DRM3/7	DRM4/8	+3.3V	COM/DRM0	GND	HND

5.8 Inverter manipulation

Start inverter after checking all below steps:

- Check that the device is fixed well on the wall.
- Make sure all the PV wiring and the AC wiring are completed.
- Make sure the meter are connected well.
- Make sure the battery is connected correctly.
- Turn on the external AC, DC switch.
- Turn on the DC switch to the 'ON' position.
- Set sysswitch on the screen of the inverter to 'Turn on'

Start inverter:

- Inverter will start automatically when the PV panel generate enough energy or the battery is charged.
- Check the status of LED and LCD screen, first LED should be green and the LCD screen should display the main interface.
- If first LED is not green please check the below:
 - All the connections are right.
 - All the external disconnect switches are closed.
 - The DC switch of the inverter is in the 'ON' position.
- Enter the setting interface.
- Set the safety standard as page 28; Set the system time as page 27; PV connection mode as page 28; Set the work mode as page 27; Set the communication address as page 28; Set the EPS as page 26; Set WIFI according to the wifi manual;



NOTE!

Please set the inverter if it is the first time to start up. Above steps is for the regular start-up of the inverter. If it is the first time to start up the inverter, you need to start up the inverter.

6 Operation method

6.1 Control panel

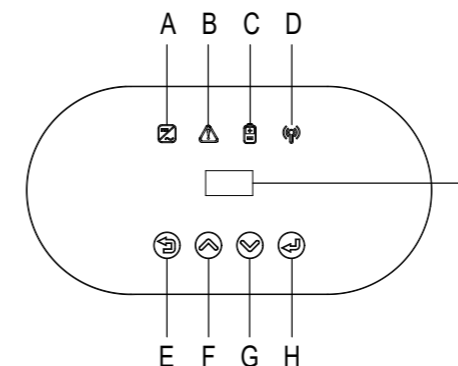

Object	Name	Description
A	Indicator LED	Green: Normal working Status.
B		Red: Fault.
C		Blue: Battery communication status.
D		Yellow: RS485 communication status.
E	Function Button	ESC button: Leave from current interface or function.
F		Up button: Move cursor to upside or increase value.
G		Down button: Move cursor to downside or decrease value.
H		OK button: Confirm the selection.
J	LCD Screen	Display the information of the inverter.

6.2 LCD function Menu structure :

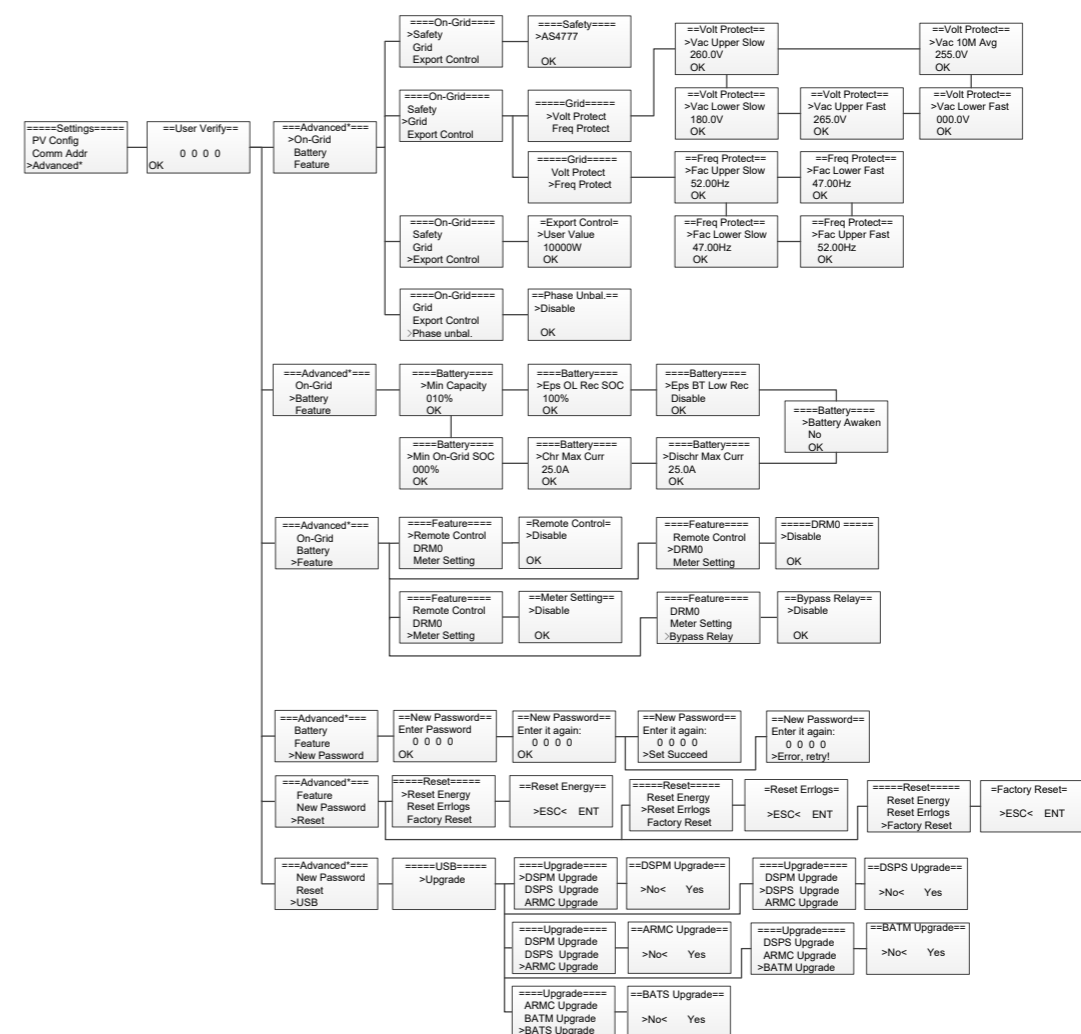
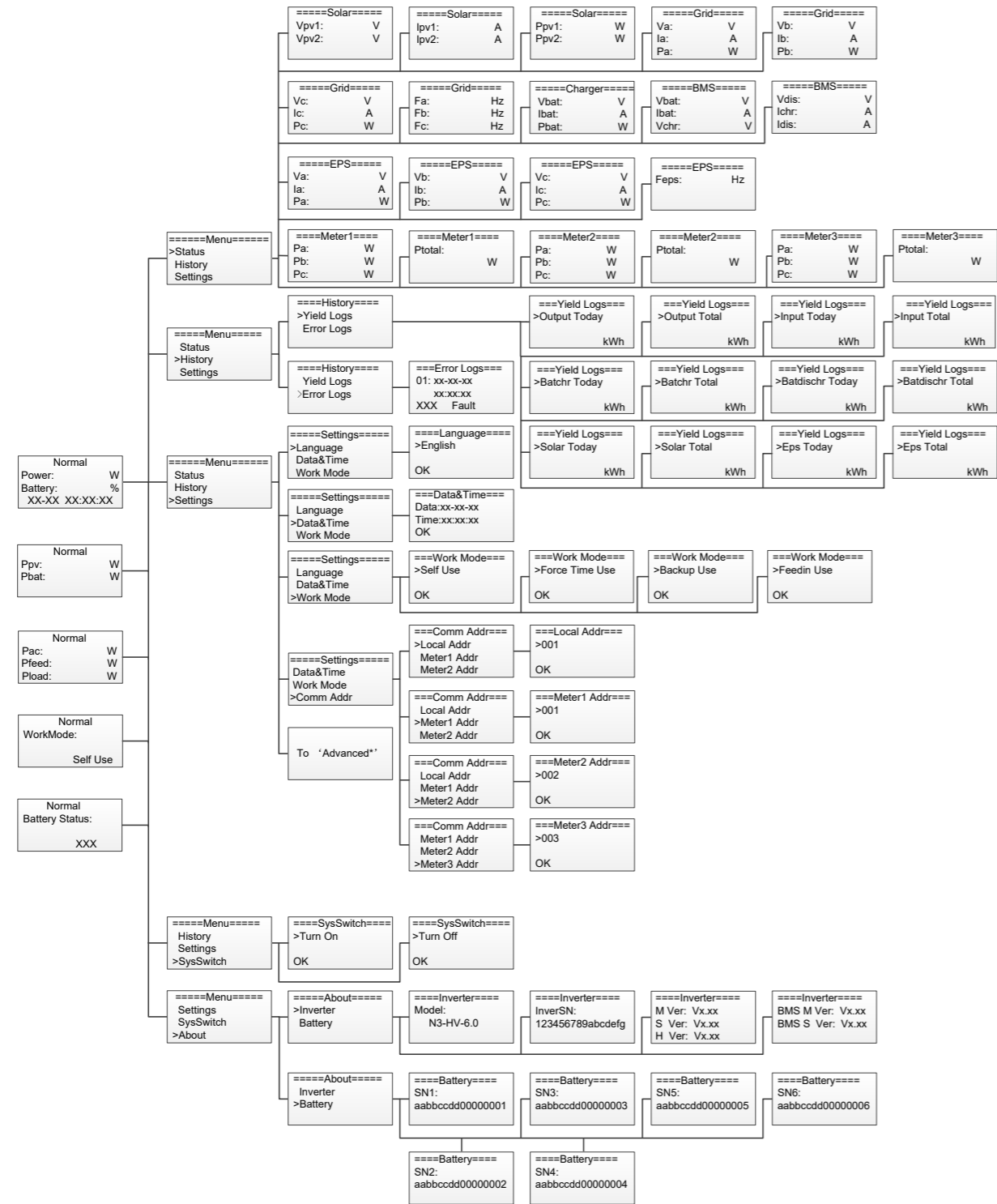

6.3 LCD operation

1. Main screen

The main screen as below. Press up or down for more information.

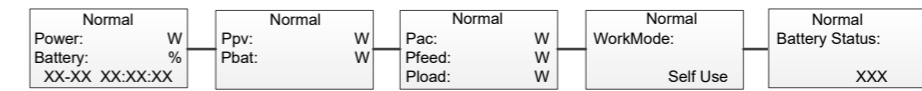

2. Status

Press 'OK' to enter the menu, check grid , solar, battery, EPS and temperature of the inverter. Press up and down to select, press 'ESC' to return to the Menu.

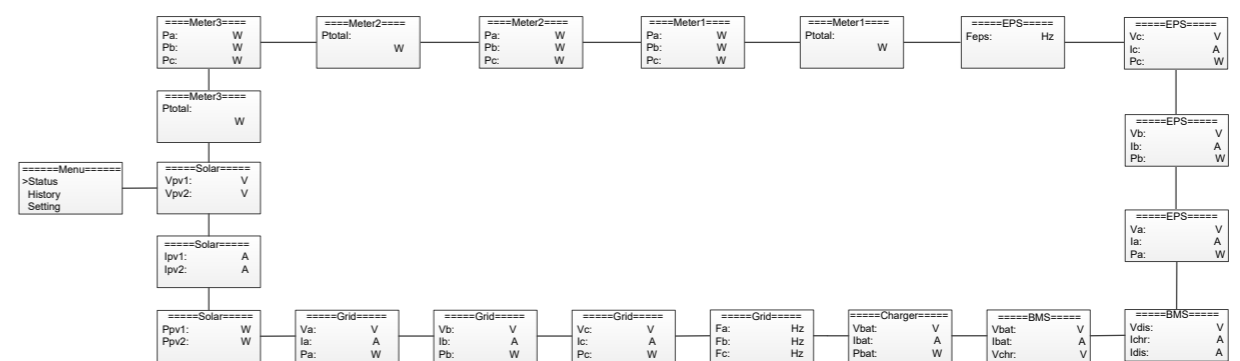

2.1) Solar

This status shows the real time PV parameters of the system. The input voltage, current and power of each PV input. Press up and down button to review the parameter. Press 'ESC' to return to status.

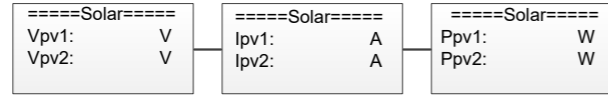

2.2) Grid

This status shows the real time grid parameters such as voltage, current, output power and frequency. Pac measures the output of the inverter.

Press up and down button to review the parameter. Press 'ESC' to return to status.

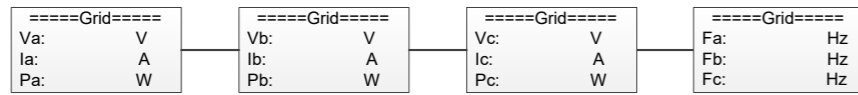

2.3) Meter

This status shows the charger situation of the system. Include the battery voltage, charge or discharge current. Charge or discharge power. '+' means in charging; '-' means in discharging. Press up and down button to review the parameter. Press 'ESC' to return to Status.

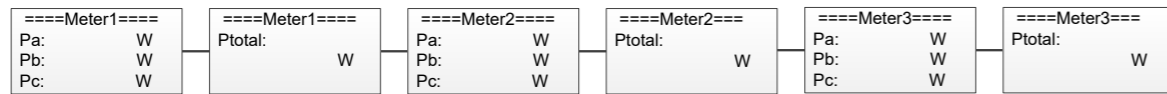

2.4) Charger

This status shows the charger situation of the system. Include the battery voltage, charge or discharge current. Charge or discharge power. '+' means in charging; '-' means in discharging. Press up and down button to review the parameter. Press 'ESC' to return to Status.

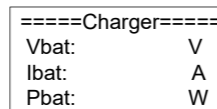

2.5) BMS

This status shows the battery situation of the system. Include the battery voltage and current, charge and discharge voltage, charge and discharge current. '+' means in charging; '-' means in discharging. Press up and down button to review the parameter. Press 'ESC' to return to Status.

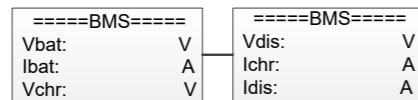

2.6) EPS

EPS will only have data when the inverter is working in EPS mode, it will show the real time data of the EPS output. As voltage, current, power, frequency. Press up and down button to review the parameter. Press 'ESC' to return to Status.

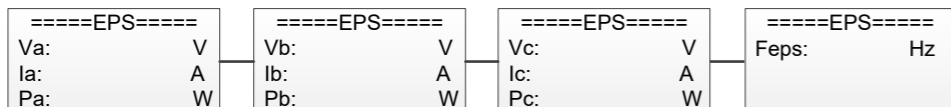

3. History

The history function contains three aspects of the information: inverter yield, battery yield and error log. Press up and down to select, and review the data of system, press 'ESC' to return to the Menu.

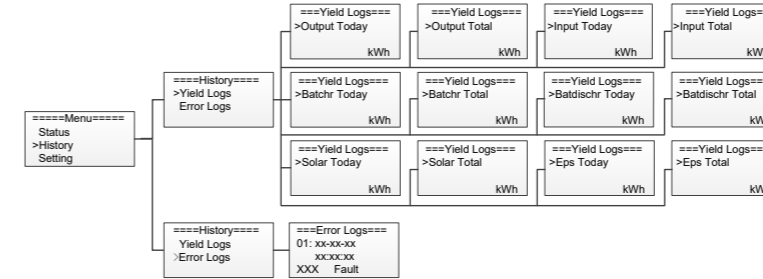

4. Settings

Setting function is used for set the inverter for language, date and time, work mode, communication address, advanced and so on.

4.1) Language

Press up or down button to change language. Press 'OK' to confirm.



4.2) Date Time

Press up or down button to change date and time. Press 'OK' to confirm.

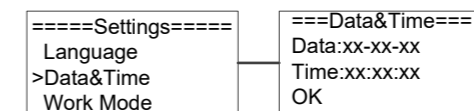

4.3) Work Mode

Press up or down button to select different work modes. Press 'OK' to confirm.

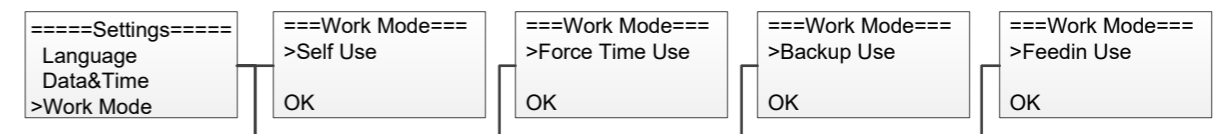

4.4) Communication Address

Press up or down button to change address of local and meter. Press 'OK' to confirm.

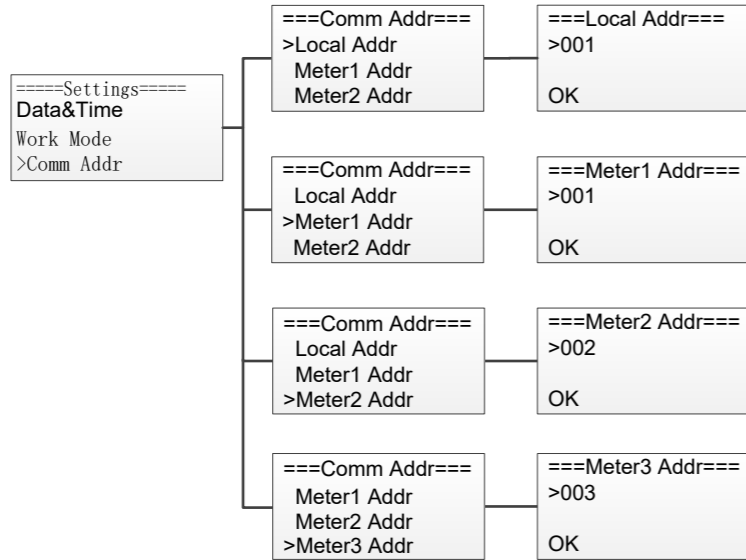

4.5) Advanced settings require the original password '0000', Press 'OK' to confirm.

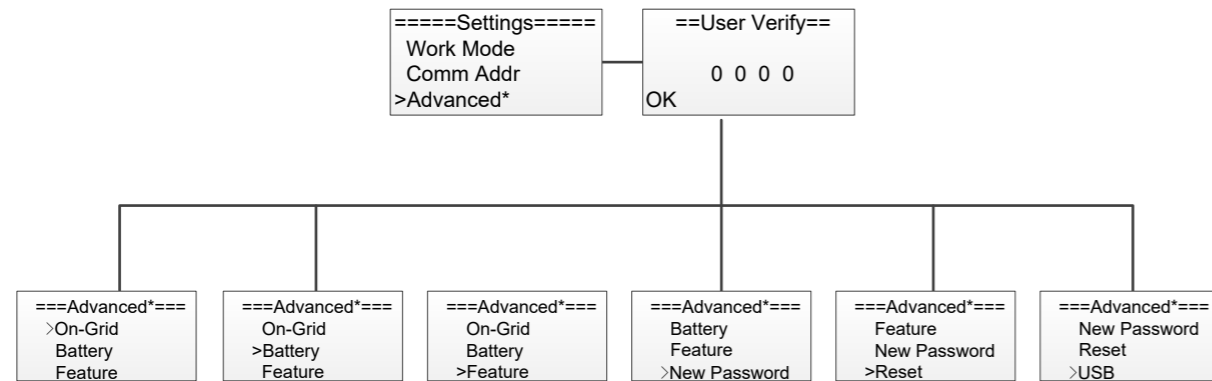

4.5.1) On-Grid

Press up or down button to set the grid functions. Press 'OK' to confirm.

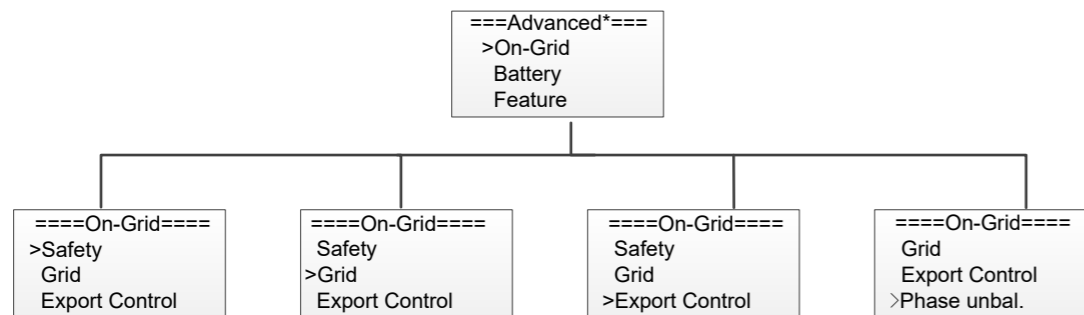

4.5.1.1) Safety

Press up or down button to change the grid code. Press 'OK' to confirm.

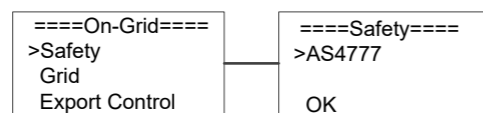

4.5.1.2) Grid

Press up or down button to change the value of grid voltage and grid frequency protect. Press 'OK' to confirm.

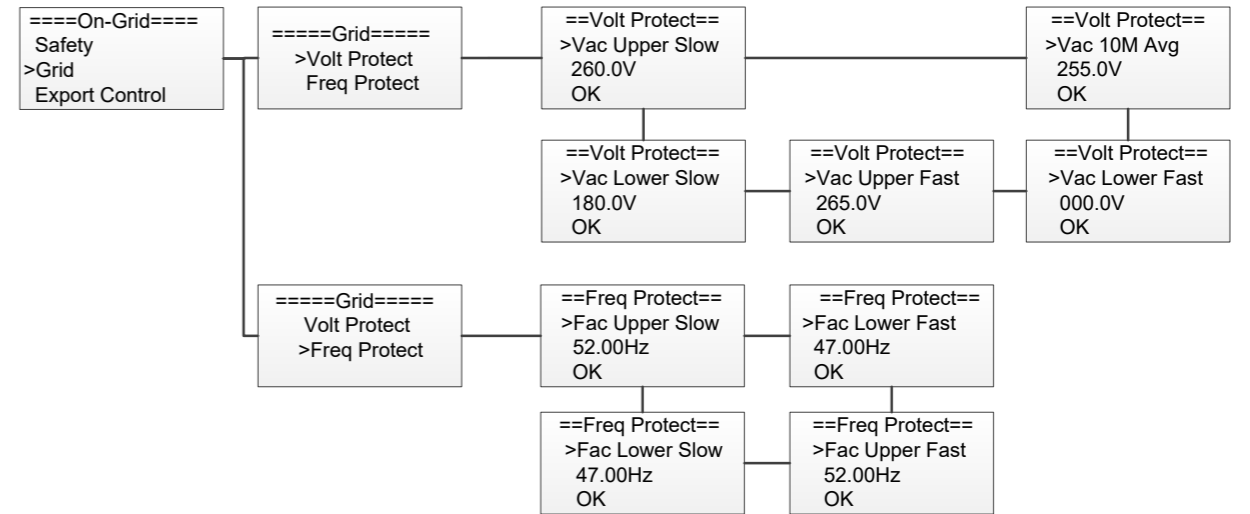

4.5.1.3) Export control

With this function the inverter can control the energy export to the grid. Press up or down button to change the export power. Press 'OK' to confirm..

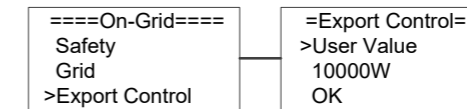

4.5.1.4) Phase unbal

When the system is connected with three-phase unbalanced load or single-phase load, customers can enable the phase unbalance function, the inverter can detect and identify the three-phase current unbalance in the system through the meter and output unbalanced power to different phase.

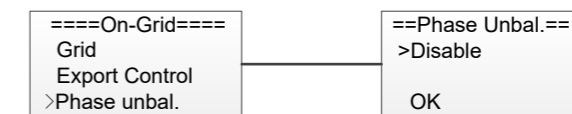

4.5.2) Battery

Press up or down button to set the parameters of battery. 'Eps BT Low Rec' means recovery enable switch when battery low capacity in EPS mode, 'Eps OL Rec SOC' means EPS overload due to low capacity for battery, if recovered, min soc. Press 'OK' to confirm.

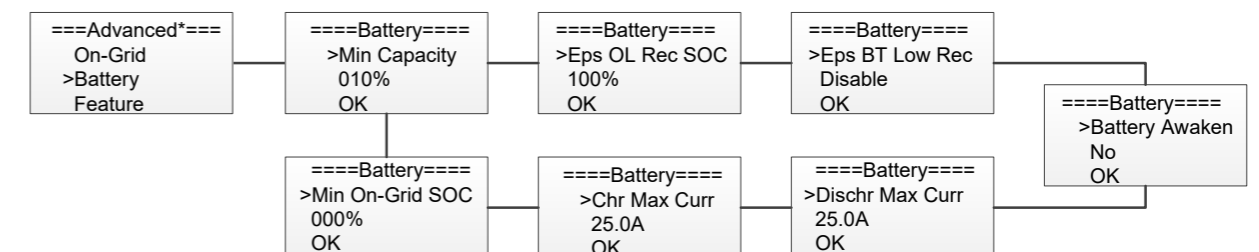

4.5.3) Feature

Press up or down button to enable or disable remote control, DRM0, and Meter. Press 'OK' to confirm.

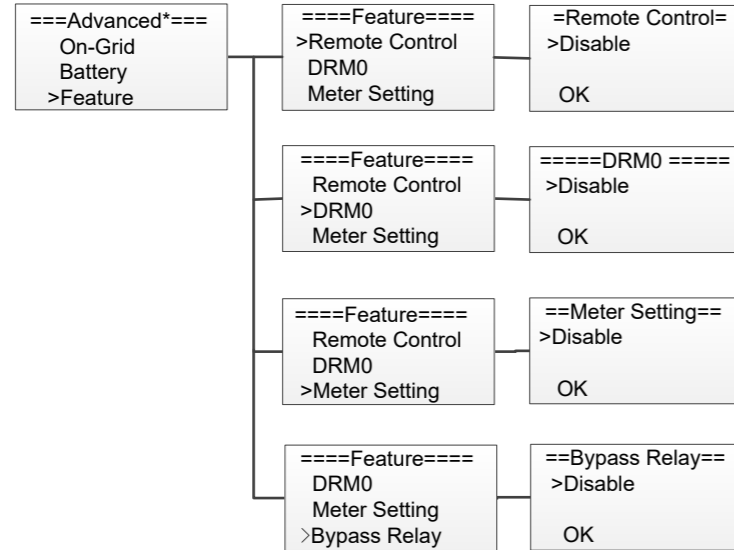

4.5.4) New Password

Press up or down button to set new password. Press 'OK' for more than 3 seconds to confirm.

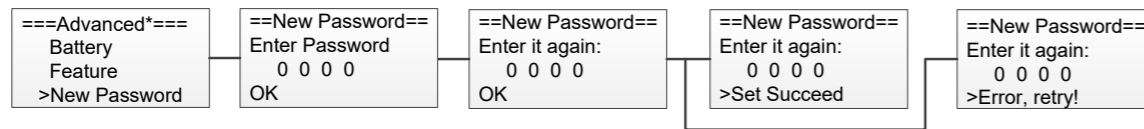

4.5.5) Reset

Press up or down button to reset energy, reset errors or factory reset. Press 'OK' to confirm.

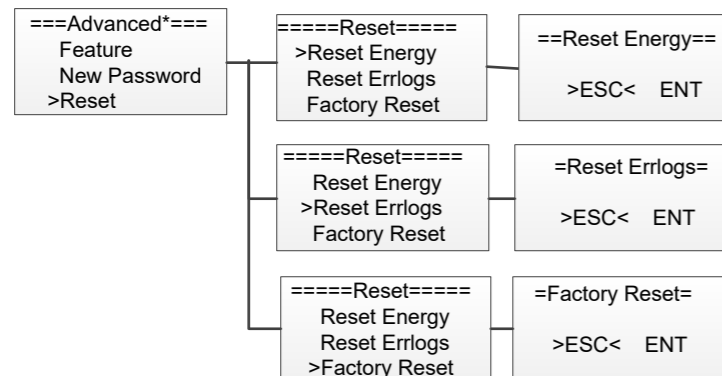

4.5.6) USB

Press up or down button to upgrade DSPM, DSPS, ARMC, BATM or BATS. Press 'OK' to confirm.

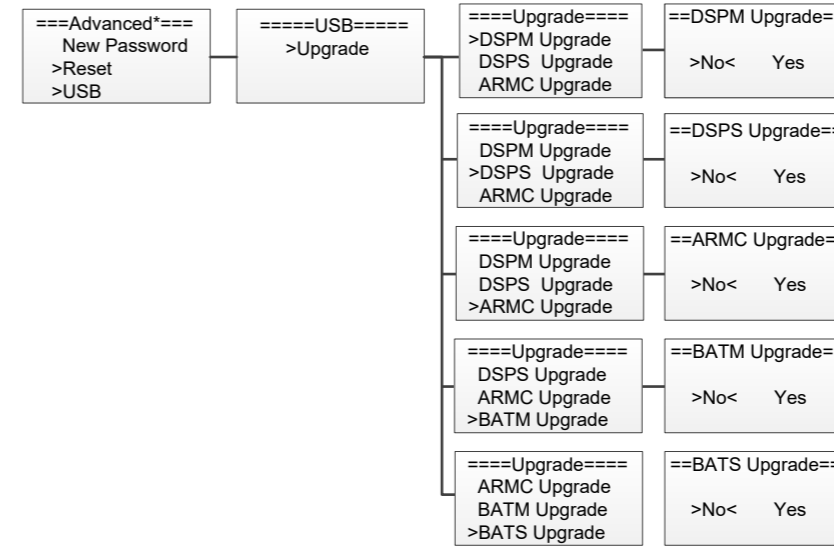

5. System Switch

Press up or down button to turn on or turn off the inverter. Press 'OK' to confirm.

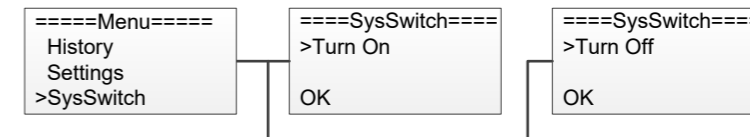

6. About

This interface shows the information of the inverter, such as series number and software version.

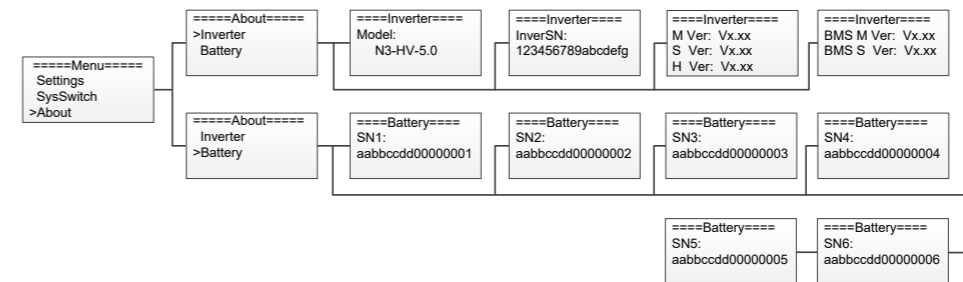

7 Troubleshooting

This section contains information and procedures for solving possible problems with the N3 HV series inverters, and provides you with trouble shooting tips to identify and solve most problems that could occur with the N3 HV series inverters.

This section will help you narrow down the source of any problems you may encounter. Please read the following trouble-shooting steps.

- Check the warning or fault messages on the System Control Panel or Fault codes on the inverter information panel. If a message is displayed, record it before doing anything further.
- Attempt the solution indicated in below table.

HW Protect Fault	Inverter over current or battery over current or PV over current detected by hardware. <ul style="list-style-type: none"> • Disconnect PV, grid and battery, then reconnect. • Or seek help from us, if not go back to normal state.
Grid Lost Fault	Grid is lost. <ul style="list-style-type: none"> • System will reconnect if the utility is back to normal. • Or seek help from us, if not go back to normal state.
Grid Volt Fault	Grid voltage out of range. <ul style="list-style-type: none"> • System will reconnect if the utility is back to normal. • Or seek help from us, if not go back to normal state.
Grid Freq Fault	Grid frequency out of range. <ul style="list-style-type: none"> • System will reconnect if the utility is back to normal. • Or seek help from us, if not go back to normal state.
PV Volt Fault	PV voltage out of range. <ul style="list-style-type: none"> • Please check the output voltage of PV panels. • Or seek for help from us.
Bus Volt Fault	Bus voltage out of range detected by hardware. <ul style="list-style-type: none"> • Disconnect PV, grid and battery, then reconnect. • Or seek help from us, if not go back to normal state.
Bat Volt Fault	Battery voltage fault. <ul style="list-style-type: none"> • Check if the battery input voltage is within the normal range. • Or seek help from us.
Vgrid 10M Fault	The grid voltage is out of range for the last 10 Minutes. <ul style="list-style-type: none"> • System will reconnect if the utility is back to normal. • Or seek help from us, if not go back to normal state.
DCI OCP Fault	DC component is out of limit in output current. <ul style="list-style-type: none"> • Disconnect PV, grid and battery, then reconnect. • Or seek help from us, if not go back to normal state.
DCV OVP Fault	DC component is out of limit in output voltage. <ul style="list-style-type: none"> • Disconnect PV, grid and battery, then reconnect. • Or seek help from us, if not go back to normal state.
SW OCP Fault	Output current high detected by software. <ul style="list-style-type: none"> • Disconnect PV, grid and battery, then reconnect. • Or seek help from us, if not go back to normal state.
RC OCP Fault	The residual current is high. <ul style="list-style-type: none"> • Please check if the insulation of electric wires is damaged. • Wait for a while to check if back to normal. • Or seek for help from us.
Iso Check Fault	The isolation is failed. <ul style="list-style-type: none"> • Please check if the insulation of electric wires is damaged. • Wait for a while to check if back to normal. • Or seek for help from us.
Temp Over Fault	The inverter temperature is high. <ul style="list-style-type: none"> • Please check if the environment temperature. • Wait for a while to check if back to normal. • Or seek for help from us.
BatConDir Fault	The battery connection is reversed. <ul style="list-style-type: none"> • Check if the positive pole and negative pole of battery are correctly connected. • Or seek help from us.

AD Sample Fault	The sample value between master and slave is not consistent. <ul style="list-style-type: none"> • Disconnect PV, grid and battery, then reconnect. • Or seek help from us, if not go back to normal state.
EPS Over Load	Over load in off grid mode. <ul style="list-style-type: none"> • Please check if the eps load power exceeds the limit. • Or seek for help from us.
Bat Low Fault	The battery power is low. <ul style="list-style-type: none"> • Wait the battery to be recharged. • Or seek for help from us.
ByPassRelayFault	By pass relay fault <ul style="list-style-type: none"> • Disconnect PV, grid and battery, then reconnect. • Or seek help from us, if not go back to normal state.
SPI CommFault	The communication between master and slave fault <ul style="list-style-type: none"> • Disconnect solar power PV+ , PV- and battery, reconnect them. • Or seek help from us, if cannot go back to normal state.
BMS_Lost	The communication between BMS and Inverter is interrupted. <ul style="list-style-type: none"> • Check if the communication cable between BMS and Inverter is correctly and well connected.
Inter Fan Fault	Fan Device Fault <ul style="list-style-type: none"> • Disconnect solar power PV+ , PV- and battery, reconnect them. • Check if the fan is stopped by dust or other foreign. • Or seek help from us, if cannot go back to normal state.
AC HCT Fault	AC Current Sensor Fault <ul style="list-style-type: none"> • Disconnect solar power PV+ , PV- and battery, reconnect them. • Or seek help from us, if cannot go back to normal state.
Inv EEPROM Fault	The master eeprom is fault. <ul style="list-style-type: none"> • Disconnect PV, grid and battery, then reconnect. • Or seek help from us, if not go back to normal state.
GFCI HW Fault	The residual current circuit is fault. <ul style="list-style-type: none"> • Please check if the insulation of electric wires is damaged. • Wait for a while to check if back to normal. • Or seek for help from us.
EPS Relay Fault	The EPS relay always keep open. <ul style="list-style-type: none"> • Disconnect PV, grid and battery, then reconnect. • Or seek help from us, if not go back to normal state.
Grid Relay Fault	The grid relay always keep close. <ul style="list-style-type: none"> • Disconnect PV, grid and battery, then reconnect. • Or seek help from us, if not go back to normal state.
Other Dev Fault	Other device fault. <ul style="list-style-type: none"> • Turn off the PV, battery and grid , reconnect them. • Or seek for help from us if cannot back to normal.
Mgr EEPROM Fault	The manager eeprom is fault. <ul style="list-style-type: none"> • Disconnect PV, grid and battery, then reconnect. • Or seek help from us, if not go back to normal state.

Meter Lost Fault	The communication between meter and Inverter is interrupted. • Check if the communication cable between meter and Inverter is correctly and well connected.
Dsp Lost Fault	SCI communication fault • Disconnect solar power PV+, PV- and battery, reconnect them. • Or seek help from us, if cannot go back to normal state.
BMS Volt Fault	Battery voltage sensor error • Wait for 5 minutes,, check again. • Or seek help from us, if not go back to normal state.
BMS Tepr Fault	Battery temperature sensor error • Wait for 5 minutes,, check again. • Or seek help from us, if not go back to normal state.
BMS IN_COM Fault	BMS internal communication fault. • Disconnect battery, check wiring between inverter and battery, battery internal wiring then reconnect. • Or seek help from us, if not go back to normal state.
BMS Dcov Fault	Battery input over voltage error • Wait for 5 minutes,, check again. • Or seek help from us, if not go back to normal state.
BMS RV Fault	Battery input transposition error • Wait for 5 minutes,, check again. • Or seek help from us, if not go back to normal state.
BMS Relay Fault	The battery relay is fault. • Disconnect battery, then reconnect. • Or seek help from us, if not go back to normal state.
BMS Cell Fault	Battery cell error • Wait for 5 minutes,, check again. • Or seek help from us, if not go back to normal state.
BMS Other Fault	Battery other error • Wait for 5 minutes,, check again. • Or seek help from us, if not go back to normal state.
BMS Protect OV	Battery over voltage protect • Wait for 5 minutes,, check again. • Or seek help from us, if not go back to normal state.
BMS Protect LV	Battery under voltage protect • Wait for 5 minutes,, check again. • Or seek help from us, if not go back to normal state.
BMS Protect ChrOC	Battery over current charging protect • Wait for 5 minutes,, check again. • Or seek help from us, if not go back to normal state.

BMS Protect DischargeOC	Battery over current discharging protect • Wait for 5 minutes,, check again. • Or seek help from us, if not go back to normal state.
BMS Protect TemHigh	Battery temperature is high • Wait for 5 minutes,, check again. • Or seek help from us, if not go back to normal state.
BMS Protect TemLow	Battery temperature is low • Wait for 5 minutes,, check again. • Or seek help from us, if not go back to normal state.

Remark

If your inverter's information panel is not displaying a Fault light, check the following list to make sure that the present state of the installation allows proper operation of the unit.

- Is the inverter located in a clean, dry, and adequately ventilated place?
- Have the DC input breakers been opened?
- Are the cables adequately sized and short enough?
- Are the input and output connections and wiring in good condition?
- Are the configurations settings correct for your particular installation?
- Are the display panel and the communications cable properly connected and undamaged?

Contact Renac Power Customer Service for further assistance. Please be prepared to describe details of your system installation and provide the model and serial number of the unit.

8 Decommissioning

8.1 Dementling the inverter

- Disconnect the inverter from DC input and AC output.
- Disconnect battery wiring.
- Wait for 5 minutes for de-energizing.
- Disconnect communication and optional connection wiring.
- Remove the inverter from the bracket.

8.2 Packaging

If possible, please pack the inverter with the original packaging.

If it is no longer available, you can also use an equivalent carton that meets the following requirements.

- Suitable for loads more than 25kg.
- With handle.
- Can be fully closed.

8.3 Storage

Store the inverter in dry place where ambient temperatures are always between -20 °C - +60 °C.

8.4 Maintenance

Inverters generally do not need any daily or routine maintenance. Heat sink should not be blocked by dust, dirt or any other items. Before the cleaning, make sure that the DC SWITCH is turned OFF and the circuit breaker between inverter and electrical grid is turned OFF. Wait at least for 5 minutes before the Cleaning.

- Check that if the cooling fins on the rear of house are covered by dirt, and the machine should be cleaned and absorbed dust when necessary. This work shall be checked time to time.
- Check that if the indicators of the inverter are in normal state, check if the keys of the inverter are in normal state, check if the display of the inverter is normal. This check should be performed at least every 6 months.
- Check that if the input and output wires are damaged or aged. This check should be performed at least every 6 months.
- You should keep the inverter panels clean and their security checked at least every 6 months.

8.5 Disposal

When the inverter or other related components need to be disposed. Have it carried out according to local waste handling regulations. Please be sure to deliver wasted inverters and packing materials to certain site, where can assist relevant department to dispose and recycle.

SMART ENERGY FOR BETTER LIFE

The logo for RENAC, featuring the word "RENAC" in a bold, blue, sans-serif font. The letter "N" is stylized with a small orange triangle pointing upwards from its top-left corner.

RENAC POWER TECHNOLOGY CO., LTD.

Block C-12, No. 20 Datong Road, Comprehensive Bonded Zone, Suzhou Hi-Tech District, Suzhou, China

Tel: +86-0512-66677278

info@renacpower.com

www.renacpower.com