



R3 Plus Series

NAC70K/NAC75K/NAC80K



Renac Power Technology Co.,Ltd.

Table of Contents

| | |
|---|----|
| 1. Introduction for Signs | 5 |
| 2. Introduction..... | 6 |
| 2.1 Preface..... | 6 |
| 2.2 PV Grid-connected Generating System | 6 |
| 2.3 How to Use This Manual | 7 |
| 3. Safety Instructions | 8 |
| 4. Overall Introduction..... | 9 |
| 4.1 Circuit Structure | 9 |
| 4.2 Description for External Interface..... | 10 |
| 5. System Operation..... | 11 |
| 5.1 System Mode..... | 11 |
| 5.2 Grid-connected Operation | 12 |
| 5.3 System Shutdown | 13 |
| 5.4 Error and Alarm..... | 13 |
| 5.5 Type of system faults and solutions | 15 |
| 6. Human-machine Interface..... | 18 |
| 6.1 LCD controlled panel | 18 |
| 6.2 Networking for monitoring | 19 |
| 6.3 Dry contact..... | 20 |
| 6.4 Remote control | 20 |
| 7. LCD Operation Menu | 21 |
| 7.1 Initialization | 21 |
| 7.2 Major cycle menu..... | 21 |
| 7.3 User interface | 23 |
| 7.4 Setting | 23 |
| 7.4.1 Input mode..... | 24 |
| 7.4.2 Standard for electric network | 24 |
| 7.4.3 Remote CTRL..... | 24 |

| | |
|---|----|
| 7.4.4 Working parameters..... | 25 |
| 7.4.5 485 address..... | 31 |
| 7.4.6 485 baudrate..... | 31 |
| 7.4.7 485 protocol..... | 32 |
| 7.4.8 Display language | 32 |
| 7.4.9 LCD backlight..... | 32 |
| 7.4.10 Date/time..... | 33 |
| 7.4.11 History clearing..... | 33 |
| 7.4.12 Password setting..... | 33 |
| 7.4.13 Maintenance..... | 34 |
| 7.4.14 Factory Reset..... | 34 |
| 7.4.15 Array detection..... | 34 |
| 7.4.16 Three-phase system..... | 35 |
| 7.5 Inquiry | 36 |
| 7.5.1 INV MODEL..... | 36 |
| 7.5.2 MODEL SN..... | 36 |
| 7.5.3 Firmware..... | 37 |
| 7.5.4 RECORD..... | 37 |
| 7.5.5 ERROR EVENT..... | 38 |
| 7.6 Statistics | 39 |
| 7.6.1 Time statistics..... | 39 |
| 7.6.2 Times of paralleling in..... | 40 |
| 7.6.3 Power peak..... | 40 |
| 7.6.4 Generated energy of that day..... | 40 |
| 7.6.5 Generated energy of that week..... | 40 |
| 7.6.6 Generated energy of that month..... | 41 |
| 7.6.7 Generated energy of that year..... | 41 |
| 7.6.8 Gross generation..... | 41 |
| 8. Installation | 42 |
| 8.1 Overview | 42 |
| 8.2 Mechanical installation..... | 43 |

- 8.2.1 Installation introductions.....43
- 8.2.2 Mechanical dimension.....43
- 8.2.3 Packing.....44
- 8.2.4 Installation of Inverter.....44
- 8.2.5 Installation Location.....45
- 8.2.6 Installation Procedure.....45
- 8.2.7 Ambient requirement.....47
- 8.3 Electric connection..... 47
 - 8.3.1 Requirement for electric installation.....47
 - 8.3.2 Wire for alternating current connection.....48
 - 8.3.3 Wire for direct current connection.....48
 - 8.3.4 Wire for communication connection.....49
- 8.4 Starting and closing..... 51
- 9. Technical Data 52
- 10. Appendix 55
 - 10.1 Quality assurance..... 55

1. Introduction for Signs

In order to make a better use of this manual, please read the following sign explanation carefully.



Warning!

This sign indicates that it may cause danger to safety of users and/or attentions or instructions for possible serious damage to hardware.



Instruction!

This sign indicates important attentions required for good operation of the system.

2. Introduction

2.1 Preface

Dear users, thank you for using photovoltaic grid-connected inverter products manufactured by our company which is experienced in development of photovoltaic grid-connected generating sets. We hope this product can meet your demands and welcome you to put forward more suggestions on performance and functions of this product.

2.2 PV Grid-connected Generating System

The photovoltaic grid-connected generating system is consist of solar cell module, grid-connected inverter, metering devices and power distribution system (as shown in Figure 1). The solar energy is converted to DC electric power through solar cell module, which is further converted into the same AC power as the grid voltage ,frequency and phase by grid-connected inverter, and fed into the grid. The photovoltaic grid-connected inverter is the key equipment in the solar power system.



Figure 1: Schematic picture of the PV Grid-Connected Generating System.

2.3 How to Use This Manual

This manual aims to provide detailed product information and installation & use instructions for users of photovoltaic grid-connected inverter manufactured by this company.

Please read this manual carefully prior to use of this product and store it properly in a place where it is convenient for installation, operation and available for maintenance personnel.

3. Safety Instructions

- * Please read this manual carefully prior to installation. This company assumes no responsibility for quality assurance upon equipment damage due to installation failing to follow instructions in this manual.
- * All operations and wiring shall be conducted by professional electrical or mechanical engineer.
- * Do not move other parts inside the machine case except the binding post during installation.
- * All electrical installations must conform to local standards for electrical installation.
- * Please contact with local appointed personnel for system installation and maintenance if this equipment requires the maintenance.
- * Use of this equipment for grid-connected power generation must be approved by local power supply departments.
- * When the photovoltaic array is installed in the day, it shall be covered with lightproof materials; otherwise the array end will subject to high voltage under exposure of sunlight, thus causing personal risk.



Warning!

Ensure that the input DC voltage does not exceed 1100V since higher input voltage may damage this equipment permanently and causing other losses, under which circumstance, this company assumes no responsibility for quality assurance and joint responsibility.

4. Overall Introduction

4.1 Circuit Structure

Figure 2 shows main circuit of inverter through which the direct current pass through the DC/DC inverter, DC/AC inverter and the filter in turn and finally output to the grid. To make the photovoltaic array generate in maximum power, the new type power devices are adopted for this machine and the advanced MPPT algorithm is used at the DC side.

System Block Diagram

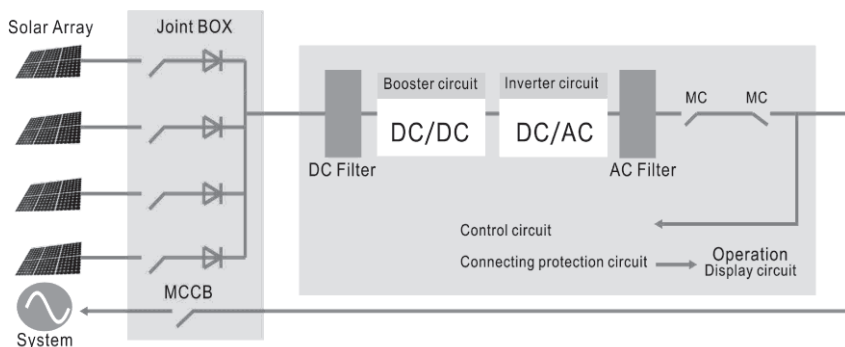

Figure 2: Main Circuit of Inverter

4.2 Description for External Interface

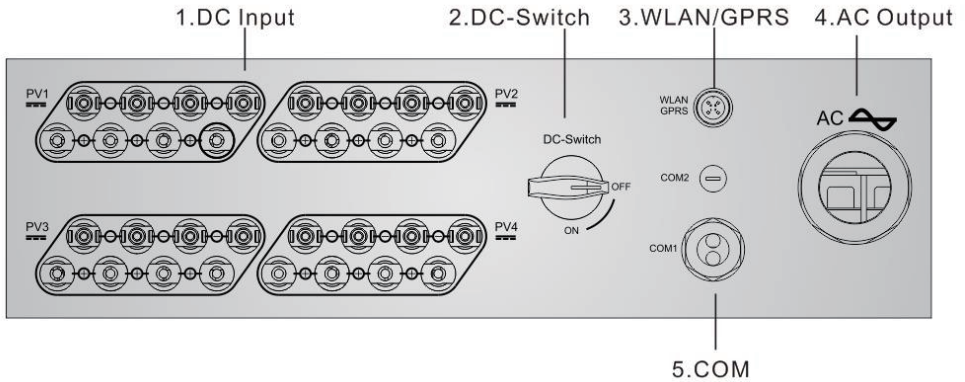

Figure 3: Interface of Inverter

■ Instructions for Interface

- * 1: DC Input: DC input terminal, connected to positive and negative electrode input of photovoltaic array respectively.
- * 2: DC switch: can judge the positive and negative electrode input of photovoltaic array.
- * 3: WLAN/GPRS.
- * 4: AC OUTPUT: AC output, spaced by three phases AC switch and connected to L1, L2, L3 and GND of three-phase grid.
- * 5: COM: wire RS485A/B is connected with PC via converter RS485/RS232. (When two or more inverters are in parallel communication, 2P DIP switch beside RJ45 of the last one should be “ON”. Or else, it may cause communication interruption. That 2P DIP switch is on, means connecting a 120Ω communication terminal resistance between the R/T+ and R/T -).

5. System Operation

5.1 System Mode

The operation modes of grid-connected type inverter include the initialization, waiting, self-checking, grid-connected operating and error modes.

- * Initialization mode: the internal data will be initialized upon power on of controller.
- * Waiting mode: the inverter will be under waiting mode if the output voltage of PV battery board is low and it has not detected any fault.
- * Self-checking mode: self-checking will be conducted by inverter each time prior to grid-connected operation. The inspection items include: inspection on insulation impedance at DC side, self-checking for leakage current self-check for invert bridge and inspection on AC output relay.
- * Grid-connected operating mode: the direct current of PV battery board is converted to alternating current by the inverter for grid-connected operation. The advanced MPPT algorithm is adopted for controller, making the inverter operating at the maximum power point of PV arrays.
- * Error mode: the inverter will enter error mode when grid voltage/frequency is abnormal or fault arises during grid-connected process. At this time, it will stop transformation of electric energy and cut away from the grid.

5.2 Grid-connected Operation

Prior to grid connection of the inverter, please confirm if the wirings among input side of inverter, PV arrays, output side and power grid are all correct. Two kinds of modes are optional for connection between DC input side of grid-connected inverter and PV arrays:

- * Independent input mode: four groups of different PV arrays may be connected to input end of inverter and independent MPPT controller is available for each group of PV arrays to control grid-connected operation.

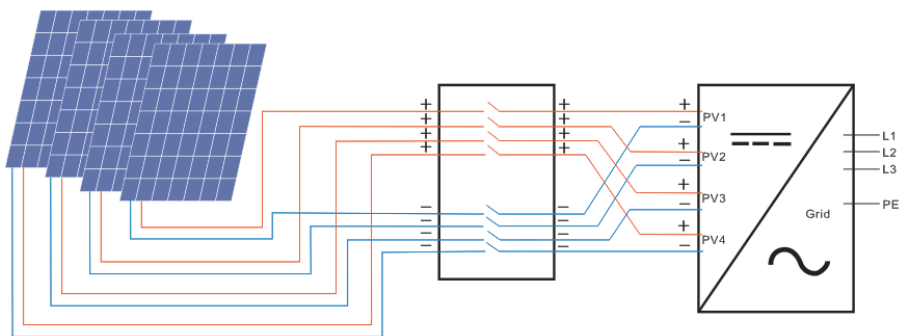

Figure 4: Independent Input Mode

- * Parallel input mode: only one group of PV arrays is connected with input end of the inverter, which is then connected to input side of inverter via four groups of parallel input terminals.

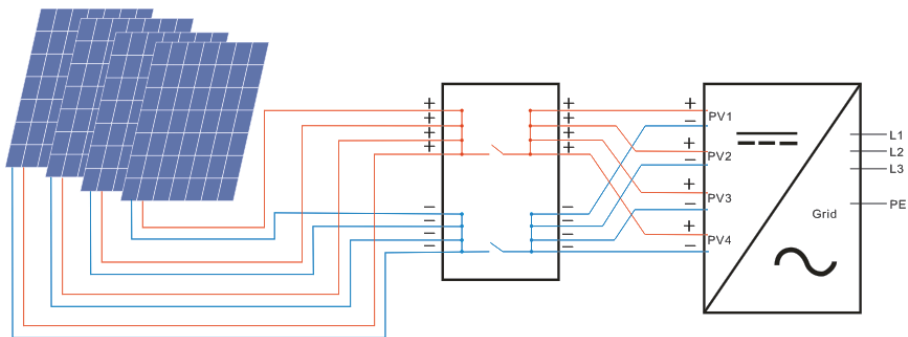

Figure 5: Parallel Input Mode



Users are required to set the item “InpuMode” under LCD menu correctly based on actual conditions of photovoltaic generating system and confirm that the mode of connection at input side is consistent with setting (refer to 7.4.1).

If both input and output wirings are correct and the power grid is free of abnormal conditions, the inverter will enter waiting mode. The grid connection of inverter will be started fully automatic. After PV voltage is higher than V_{pv} , count down for grid connection will be started automatically for controller and prepare for grid-connected operation after delayed for T_d . Manual setting is available for both V_{pv} and T_d through LCD panel.

5.3 System Shutdown

If grid-connected power of inverter is smaller than 100W continuously, the alarm of “zero power” will emerge. After alarming for one minute, the inverter will cut away from the grid and reenter waiting mode.

The inverter will cut away from the grid upon discovery of any abnormal condition during the grid-connected process.

5.4 Error and Alarm

The error and alarm information of photovoltaic grid-connected inverter refer to the following table:

Table 5.1 Working conditions and fault/alarm message

| Working conditions | Message display in English | Description |
|-----------------------|----------------------------|--|
| Normal working status | | |
| Inverter OFF | No display | PV voltage <250V, the inverter is switched off |
| Inverter Stand-by | Stand-by | 210V< PV voltage <350V(adjustable) |
| Self-test | Checking | PV voltage >350V(adjustable), the inverter get started and self-test all modules |

| | | |
|--|------------------------|---|
| Normal Power Generation | Normal | Generate AC power and feed to municipal Grid after self-test is completed |
| Monitoring parameter display | | |
| Instant Power Rate & Volume Of Power Generated | XXXX W/ XXXXX Kwh | Instant power rate & accumulated power generated |
| Voltage And Current Of PV1/PV2/PV3/PV4 Input | DC :XXX.X V XXX.X A | Voltage and current from PV arrays |
| Voltage And Current Of AC output | AC: XXX.X V XXX.X A | Grid Voltage and current |
| System faulty display | | |
| AC Voltage Low | F00 | AC Voltage is too low. |
| AC Voltage High | F01 | AC Voltage is too high. |
| AC Frequency Low | F02 | AC frequency is too low. |
| AC Frequency High | F03 | AC frequency is too high. |
| Bus Voltage Low | F04 | Bus voltage is too low. |
| Bus Voltage High | F05 | Bus voltage is too high. |
| Bus Voltage Abnormal | F06 | BUS+ or BUS- is too high or too low on bus. |
| Insulation Impedance Low | F07 | PV arrays Insulation impedance is too low. |
| Input current high | F08 | PV Input current is too high. |
| Reserved | F09 | Reserved |
| Inverter Current High | F10 | Inverter current is too high. |
| Inverter DC Current High | F11 | Inverter DC current is too high. |
| Reserved | F12 | Reserved |
| Heatsink Temperature High | F13 | Heatsink temperature is too High. |
| AC Relay Abnormal | F14 | AC relay is abnormal. |
| PV Input Voltage Low | F15 | One of PV input is idle when inverter is set on parallel mode. |
| Remote Off | F16 | Status of inverter is on remote off. |
| Reserved | F17 | Reserved |
| SPI Communication Fault | F18 | Communication fault on control |
| Reserved | F19 | Reserved |
| Leakage Current High | F20 | Leakage current is too high. |
| Self-Checking Failure Of Leakage Current | F21 | Self-checking Failure of Leakage Current. |
| Consistency Voltage Fault | F22 | Inconsistent voltage between primary CPU and secondary CPU. |

| | | |
|-----------------------------|-----|---|
| Consistency Frequency Fault | F23 | Inconsistent frequency between primary CPU and secondary CPU. |
| DSP Operation Fault | F25 | DSP communication faulty on |
| DSP Communication Lost | F32 | DSP communication faulty on |

Table 5.2 Alarm Information

| Alarm message | Alarm | Solutions |
|-------------------------------------|-------|---|
| Speed Low Of Fan_ A | W00 | Alarm message for speed low of Fan_ A. |
| Speed Low Of Fan_ B | W01 | Alarm message for speed low of Fan_ B. |
| Speed Low Of Fan_ C | W02 | Alarm message for speed low of Fan_ C. |
| Zero Power | W03 | It is only a reminding message to show DC inputs very low and inverter is about to shut down. |
| Clock Warning | W16 | Alarm message for clock |
| Speed Low Of Fan_ 4 | W17 | Alarm message for speed low of Fan_ 4. |
| Speed Low Of Fan_ 5 | W18 | Alarm message for speed low of Fan_ 5. |
| Speed Low Of Fan_ 7 | W19 | Alarm message for speed low of Fan_ 7. |
| Speed Low Of Fan_ 8 | W20 | Alarm message for speed low of Fan_ 8. |
| Lightning protection device warning | W21 | Alarm message for Lightning protection device action |

5.5 Type of system faults and solutions

Table 5.3 Type of system faults and solutions

| Trouble Shooting | | |
|------------------|--|---|
| | Alarm Message | Solution |
| | AC voltage & frequency are too high or too low. (F00-F03) | (1)Please check mains voltage whether it is complied with local safety standard (2)Please check the AC output line is properly connected. Make sure its output voltage to see if it is normal. (3)Disconnect PV input and restart the inverter and check whether fault still exists. (4>Contact with your local distributor if the fault still exists. |
| | Bus voltage is too high or too low (F04-F05) | (1)Please check the setting of input mode. (2)Disconnect PV input and restart the inverter and check whether fault still exists. (3)Contact with your local distributor if the fault still exists. |

System
Faulty
Or
Failure
Type

| | |
|----------------------------------|---|
| Bus Voltage Abnormal (F06) | (1)Please check the setting of input mode. (2)Please try to restart inverter every few minutes for several times and check whether fault still exists. (3)Contact with your local distributor if the fault still exists. |
| Insulation impedance Fault (F07) | (1)Disconnect PV input and restart the inverter and check whether fault still exists. (2)Please measure impedance of PV+/PV- to ground whether is over than 500K Ω . (3)Please contact your local distributor if impedance is less than 500K Ω . |
| Input Current High (F08) | (1)Please check the setting of input mode (2)Disconnect PV input and restart the inverter and check whether fault still exists. (3)Contact with your local distributor if the fault still exists. |
| Hardware Current High (F09) | (1)Disconnect PV input and restart the inverter after few minutes and check whether fault still exists. (2)Contact with your local distributor if the fault still exists. |
| Inverter Current High (F10) | (1)Disconnect PV input and restart the inverter after few minutes and check whether fault still exists. (2)Contact with your local distributor if the fault still exists. |
| Inverter DC Current high (F11) | (1)Disconnect PV input and restart the inverter after few minutes and check whether fault still exists. (2)Contact with your local distributor if the fault still exists. |
| Ambient Temperature High (F12) | (1)Disconnect PV input and cool down the inverter then restart the inverter to see if it is back to normal operation. (2)Please check environmental temperature whether out of working temperature. (3)Contact with your local distributor if the fault still exists. |
| Heatsink Temperature High(F13) | (1)Disconnect PV input and cool down the inverter then restart the inverter to see if it is back to normal operation. (2)Please check environmental temperature whether out of working temperature. (3)Contact with your local distributor if the fault still exists. |
| AC Relay Fault (F14) | (1)Disconnect PV input and restart the inverter and check whether fault still exists. (2)Contact with your local distributor if the fault still exists. |
| PV Input Voltage Low (F15) | (1)Please check the configuration of PV input, one of PV input is idle when inverter is set on parallel mode. (2)Disconnect the PV input and restart the inverter and check whether fault still exists. (3)Contact with your local distributor if the fault still exists. |

| | |
|---|--|
| Remote Off (F16) | The inverter is on remote OFF status, the Inverter can be turned off/on remotely by monitoring software. |
| SPI communication Fault (F18) | (1)Disconnect PV input and restart the inverter and check whether fault still exists. (2)Contact with your local distributor if the fault still exists. |
| Leakage Current High (F20) | (1)Disconnect PV input and restart the inverter and check whether fault still exists. (2)Contact with your local distributor if the fault still exists. |
| Leakage Current Self-Checking Failure (F21) | (1)Disconnect PV input and restart the inverter and check whether fault still exists. (2)Contact with your local distributor if the fault still exists. |
| Consistency Voltage Fault (F22) | (1)Disconnect PV input and restart the inverter and check whether fault still exists. (2)Contact with your local distributor if the fault still exists. |
| Consistency Frequency Fault(F23) | (1)Disconnect PV input and restart the inverter and check whether fault still exists. (2)Contact with your local distributor if the fault still exists. |
| DSP Operation Fault(F25) | (1)Disconnect PV input and restart the inverter and check whether fault still exists. (2)Contact with your local distributor if the fault still exists. |
| DSP communication Lost (F32) | (1)Disconnect PV input and restart the inverter and check whether fault still exists. (2)Contact with your local distributor if the fault still exists. |

6. Human-machine Interface

6.1 LCD controlled panel

There are 4 buttons and 4 LEDs installed on the panel of inverter, as shown in Figure 6.

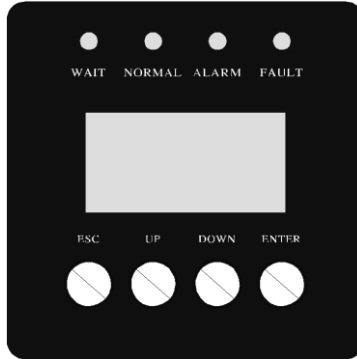

Figure 6: LCD Controlled Panel

Table 6.1 Description for LED light

| LED light | Definition |
|-----------|---|
| WAIT | Indicator light for waiting of paralleling in |
| NORMAL | Indicator light for normal operation (generating electricity) |
| ALARM | Indicator light for warning alarm |
| FAULT | Indicator light for error (fault) |

Table 6.2 Description for functions of buttons

| Buttons | Functions |
|---------|--|
| ESC | Return/Cancel/Exit |
| UP | Upwards choice menu/increase value when setting parameters |
| DOWN | Downwards choice menu/decrease value when setting parameters |
| ENTER | Enter menu/confirm set value/move cursor |



Note: press any button, backlight of LCD will last for a certain period, specific time can be set in the menu.

6.2 Networking for monitoring

The inverter is provided with various kinds of communication modes, when the user requires to monitor the running information of photovoltaic power generation system, we will offer the following design scheme for monitoring system.

■ Intelligent cluster controller:

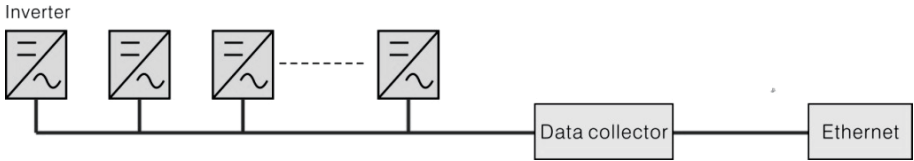

Figure 7: Data collector conducts monitoring through RS485

■ PC machine

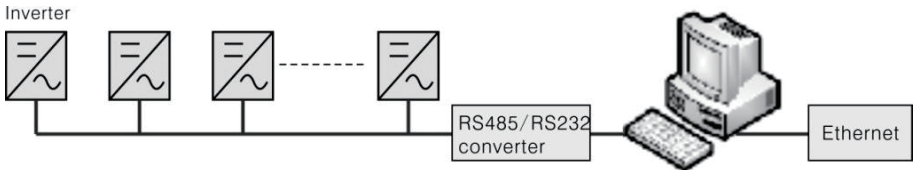

Figure 8: PC machine conducts monitoring through RS485

■ Data collector+ PC machine

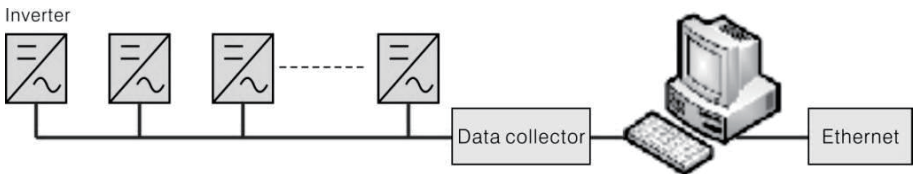

Figure 9: Data collector and PC machine conduct monitoring through RS485

Signal Pins of Inverter RS485 terminal block are defined as follow:

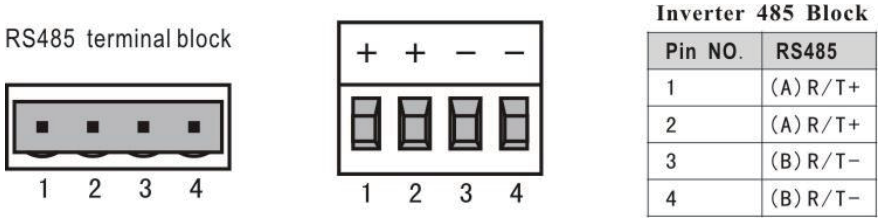

Figure 10: RS485 Port

6.3 Dry contact

Interface (optional).

6.4 Remote control

The inverter can realize the remote SHUTDOWN and ON and power limit regulatory function by the associated monitoring software.

7. LCD Operation Menu

7.1 Initialization

| Interface | Explanation |
|--|---|
| <div data-bbox="98 331 415 536" style="border: 1px solid black; padding: 10px; width: fit-content;">Initializing... Please Wait!</div> | After starting-up of inverter, LCD will firstly enter this interface, and deliver parameters required by operation of the machine to DSP. |

7.2 Major cycle menu

After initialization, LCD will enter a major cycle menu to display running information of the inverter in a circulating mode, including 10 interfaces for network voltage, frequency of electric network, etc. Time for automatic switch-over between interfaces is 3 seconds, also the interfaces can be switched manually by pressing UP or DOWN buttons, if you want to fix at a certain interface, press ENTER to lock this interface, after successful locking, a lock icon will occur at upper right corner of this interface, press ENTER button again, this interface will be unlocked, and the menu will continue to display in a circulating mode.

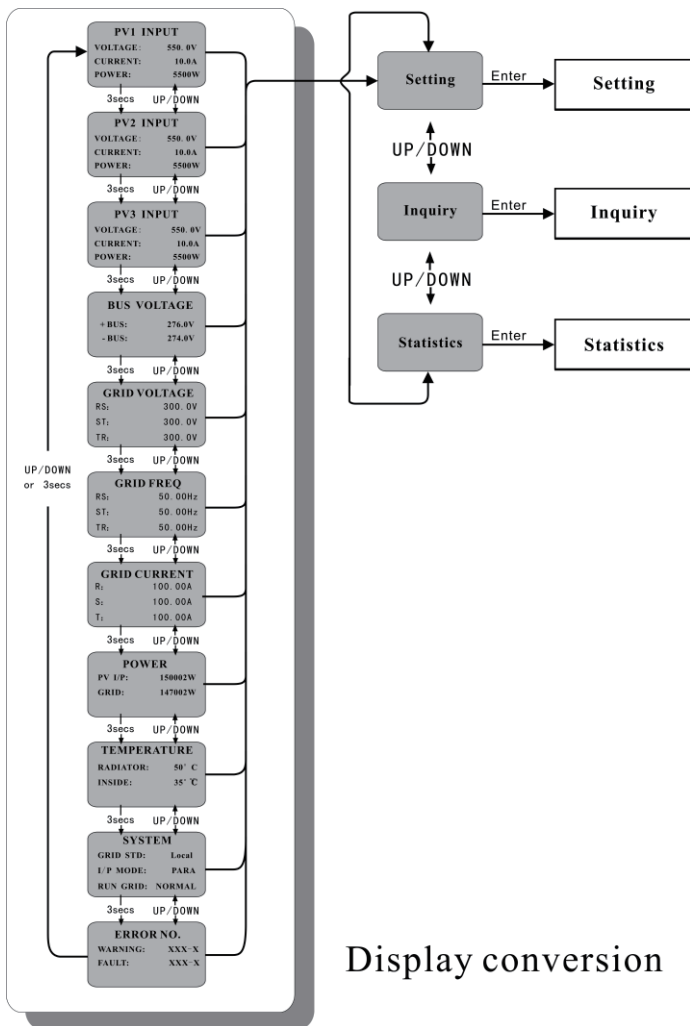

Display conversion

Figure 11: Interface of recycling display

When the menu is in an automatic cycling display mode, if error (fault) or warning alarm occurs, it will skip into system interface immediately and lock to it, and this will make convenience for the user to determine its cause based on codes on the interface. After disappearing of error (fault) or warning alarm, the menu will return to automatic circulating mode. Press ESC button to exit major circulating menu interface and enter user interface (refer to 7.3).

7.3 User interface

| Interface | Description |
|---|--|
| <pre> -----USER----- →1:Setting 2:Inquire 3:Statistics </pre> | <p>Select corresponding options by pressing UP or DOWN button, enter “setting”, “inquiry” and “statistics” menus by pressing ENTER button. Press ESC to return major circulating menu.</p> |

7.4 Setting

| Interface | Description |
|--|--|
| <pre> -----PASSWORD----- Input: <u>XXXXXX</u> </pre> | <p>After entering into the setup interface, the system will prompt to input password, the default password is “000000”, and this password can be altered Password setting menu (refer to 7.4.12); press UP/DOWN to increase or decrease the input figure, press ENTER button to move the cursor backwards, press ESC button to move the cursor forward.</p> |
| <pre> -----SETUP----- →1: INPUT MODE 2: GRID STD 3: REMOTE CTRL </pre> | <p>After successful input of password, it will enter setting option interface. Press UP/DOWN to move corresponding options, and enter the selected menu by pressing ENTER button; press ESC button to return back the user interface (refer to 7.3), there are 16 options in total, including Input mode, Grid std, Remote ctrl, Run setting, 485 address, Baud rate, Protocol, Language, Backlight, Date/Time, Clear rec, Password ,Maintenance, Fctry reset, Array detec and Three-phase system.</p> |

7.4.1 Input mode

| Interface | Description |
|---|--|
| <pre>----- INPUT MODE ----- →1:INDEPENDENT 2:PARALLEL</pre> | Press UP/DOWN button to move corresponding option. Then confirm the selected option and enter interface of please restart (refer to 7.4.4.11) by pressing ENTER button. Press ESC button to cancel choice and return back setup interface (refer to 7.4). Default option is independent. |

7.4.2 Standard for electric network

| Interface | Description |
|--|--|
| <pre>-----GRID STD----- →1: China 2:Germany 3:Australia 4:Italy 5:Spain 6:U.K.</pre> | Press UP/DOWN button to move corresponding options, including China, Germany, Australia, Italy, Spain, U.K; with 16 kinds in total. Then confirm the selected option and enter interface of please restart (refer to 7.4.4.11) by pressing ENTER button. Press ESC button to cancel choice and return back setup interface (refer to 7.4). |

7.4.3 Remote CTRL

| Interface | Description |
|---|--|
| <pre>----REMOTE CTRL ---- →1:DISABLE 2:ENABLE</pre> | Press UP/DOWN button to move corresponding options. Then confirm the selected option and return back setup interface (refer to 7.4) by pressing ENTER button. Press ESC to cancel choice and return back setup interface (refer to 7.4). Default option is disability. |

7.4.4 Working parameters

| Interface | Description |
|---|--|
| <pre>-- RUN SETTING-- →1: VPV-START 2: DELAY-START 3: VAC-MIN</pre> | Press UP/DOWN button to move corresponding options, press ENTER to enter into the selected menu; return back setup interface (refer to 7.4) by pressing ESC, there are 6 options in total, including VPV-START, DELAY-START, VAC-MIN, VAC-MAX, FAC-MIN, FAC-MAX, ACTIVE POWER, REACT POWER, FREQ POWER and V LOAD. |

7.4.4.1 Starting-up voltage

| Interface | Description |
|--|---|
| <pre>---START-UP VOLT--- INPUT: <u>350V</u> UNIT: V</pre> | Press UP/DOWN to increase or decrease the input figure, move the cursor backwards and confirm completion of input as well as enter into interface of please restart (refer to 7.4.4.11) by pressing ENTER button, press ESC to move the cursor forward and return back working interface (refer to 7.4.4); the input figure is between 250 and 850, default is 350. |

7.4.4.2 Starting-up delay time

| Interface | Description |
|---|---|
| <pre>-- START-UP DELAY-- INPUT: <u>60</u> UNIT: SEC</pre> | Press UP/DOWN to increase or decrease the input figure, confirm input and enter into interface of please restart (refer to 7.4.4.11) by pressing ENTER button; press ESC to 4 cancel input and return back working interface (refer to 7.4.4), input figure is between 60 and 300. This parameter is changed by grid standards. |

7.4.4.3 Low voltage of electric network

| Interface | Description |
|---|--|
| <div style="border: 1px solid black; padding: 5px;"><p>--GRID VOLT LOW-- INPUT: <u>450</u> UNIT: V</p></div> | Press UP/DOWN to increase or decrease the input figure, confirm input and enter into interface of please restart (refer to 7.4.4.11) by pressing ENTER button; press ESC to cancel input and return back working interface (refer to 7.4.4), input figure is between 450 and 490. This parameter is changed by grid standards. |

7.4.4.4 High voltage of electric network

| Interface | Description |
|--|--|
| <div style="border: 1px solid black; padding: 5px;"><p>-- GRID VOLT HIGH -- INPUT: <u>550</u> UNIT: V</p></div> | Press UP/DOWN to increase or decrease the input figure, confirm input and enter into interface of please restart (refer to 7.4.4.11) by pressing ENTER button; press ESC to cancel input and return back working interface (refer to 7.4.4), the input figure is between 510 and 550. This parameter is changed by grid standards. |

7.4.4.5 Low frequency of electric network

| Interface | Description |
|--|--|
| <div style="border: 1px solid black; padding: 5px;"><p>-- GRID FREQ LOW-- INPUT: <u>49.5</u> UNIT: Hz</p></div> | Press UP/DOWN to increase or decrease the input figure, confirm input and enter into interface of please restart (refer to 7.4.4.11) by pressing ENTER button; press ESC to cancel input and return back working interface (refer to 7.4.4), the input figure is between 45.0 and 49.8. This parameter is changed by grid standards. |

7.4.4.6 High frequency of electric network

| Interface | Description |
|---|--|
| <pre>-- GRID FREQ HIGH-- INPUT: <u>50.5</u> UNIT: Hz</pre> | Press UP/DOWN to increase or decrease the input figure, confirm input and enter into interface of please restart (refer to 7.4.4.11) by pressing ENTER button; press ESC to cancel input and return back working interface (refer to 7.4.4), the input figure is between 50.2 and 55. This parameter is changed by grid standards. |

7.4.4.7 Active power

| Interface | Description |
|--|---|
| <pre>-- ACTIVE POWER -- →1.PERCENT SET 2.VALUE SET</pre> | Press UP/DOWN to move corresponding options, and enter the selected menu by pressing ENTER button; press ESC button to return back working interface (refer to 7.4.4) |

7.4.4.7.1 Power limit

| Interface | Description |
|---|---|
| <pre>----POWER LIMIT---- INPUT: <u>019 %</u></pre> | Press UP/DOWN to increase or decrease the input figure, confirm input and enter into interface of Active power (refer to 7.4.4.7) by pressing ENTER button; press ESC to cancel input and return back Active power (refer to 7.4.4.7), the input figure is between 000 and 100. |

7.4.4.7.2 Power Value

| Interface | Description |
|---|--|
| <div style="border: 1px solid black; padding: 10px; width: fit-content;"> <p>---- POWER VALUE ---- INPUT: <u>066KW</u></p> </div> | <p>Press UP/DOWN to increase or decrease the input figure, confirm input and enter into interface of Active power (refer to 7.4.4.7) by pressing ENTER button; press ESC to cancel input and return back Active power (refer to 7.4.4.7), the input figure is between 0 and Pmax. (Pmax: 70K-77, 75K-75, 80K-88)</p> |

7.4.4.8 Reactive power

| Interface | Description |
|---|--|
| <div style="border: 1px solid black; padding: 10px; width: fit-content;"> <p>-- RE-POWER SET -- →1.RE-POWER CTL 2.POWER FACTOR 3.PERCENT SET</p> </div> | <p>Press UP/DOWN to move corresponding options, and enter the selected menu by pressing ENTER button; press ESC button to return back working interface (refer to 7.4.4)</p> |

7.4.4.8.1 RE-POWER CTL

| Interface | Description |
|---|---|
| <div style="border: 1px solid black; padding: 10px; width: fit-content;"> <p>--RE-POWER CTL-- →1: POWER FACTOR 2: REACT POWER 3: QV WAVE</p> </div> | <p>Press UP/DOWN button to move corresponding options. And confirm selected option and return back the Reactive power by pressing ENTER button (refer to 7.4.4.8), press ESC button to cancel choice and return back Reactive power (refer to 7.4.4.8);</p> |

7.4.4.8.2 Power factor

| Interface | Description |
|---|---|
| <pre>--POWER FACTOR-- INPUT: <u>0.000</u></pre> | Press UP/DOWN to increase or decrease the input figure, confirm input and return back Reactive power (refer to 7.4.4.8) by pressing ENTER button, press ESC button to cancel input and return back Reactive power (refer to 7.4.4.8); the input numerical value is between 0.000 and 1.200. |

7.4.4.8.3 Reactive power

| Interface | Description |
|--|--|
| <pre>-REACTIVE POWER- INPUT: <u>-26%</u></pre> | Press UP/DOWN to increase or decrease the input figure, confirm input and return back Reactive power (refer to 7.4.4.8) by pressing ENTER button, press ESC button to cancel input and return back Reactive power (refer to 7.4.4.8); the input numerical value is between -60and +60. |

7.4.4.9 Over frequency derating

| Interface | Description |
|--|--|
| <pre>----FREQ POWER---- →1.FUNC ENB 2.THRESHOLD</pre> | Press UP/DOWN button to move corresponding options, press ENTER to enter into the selected menu; return back working interface (refer to 7.4.4) by pressing ESC, there are 2 options in total, including function enable and frequency threshold . |

7.4.4.9.1 Over frequency derating enable

| Interface | Description |
|---|--|
| <div style="border: 1px solid black; padding: 5px; width: fit-content;">--FREQ POWER--- →1.ENABLE 2.DISABLE</div> | Press UP/DOWN button to move corresponding options, press ENTER to enter into the Over frequency derating interface (refer to 7.4.4.9); return back Over frequency derating interface (refer to 7.4.4.9) by pressing ESC, there are 2 options in total, including enable and disable . |

7.4.4.9.2 Frequency threshold

| Interface | Description |
|---|---|
| <div style="border: 1px solid black; padding: 5px; width: fit-content;">----THRESHOLD---- INPUT: <u>65.0</u> UNIT: Hz</div> | Press UP/DOWN to increase or decrease the input figure, confirm input and enter into interface of Over frequency derating interface (refer to 7.4.4.9) by pressing ENTER button; press ESC to cancel input and return back Over frequency derating interface (refer to 7.4.4.9).the input numerical value is between 50.2 and 65.0. |

7.4.4.10 Over voltage derating

| Interface | Description |
|--|--|
| <div style="border: 1px solid black; padding: 5px; width: fit-content;">--- V LOAD --- →1.ENABLE 2.DISABLE</div> | Press UP/DOWN button to move corresponding options, press ENTER to enter into the working interface (refer to 7.4.4); return back working interface (refer to 7.4.4) by pressing ESC, there are 2 options in total, including enable and disable . |

7.4.4.11 Please restart

| Interface | Description |
|----------------------------|---|
| <pre>Please Restart!</pre> | A prompt that it is required to start the machine once again, so that the setup relevant to working will be effective, and it will return back working interface (refer to 7.4.4) within 2 seconds. |

7.4.5 485 address

| Interface | Description |
|--|--|
| <pre>-----485 ADDRESS----- INPUT: 1</pre> | Press UP/DOWN to increase or decrease the input figure, confirm input and return back setup interface (refer to 7.4) by pressing ENTER button, press ESC button to cancel input and return back setup interface (refer to 7.4); the input numerical value is between 1 and 64. |

7.4.6 485 baudrate

| Interface | Description |
|--|---|
| <pre>-----SELECT----- →1:2400 bps 2:4800 bps 3:9600 bps</pre> | Press UP/DOWN button to move corresponding options. And confirm selected option and return back the setup interface by pressing ENTER button (refer to 7.4), press ESC button to cancel choice and return back setup interface (refer to 7.4); options include 2400, 4800, 9600 and 19200, with 4 in total. |

7.4.7 485 protocol

| Interface | Description |
|--|--|
| <pre>-----SELECT----- →1: MODBUS</pre> | Press UP/DOWN button to move corresponding options. And confirm selected option and return back the setup interface by pressing ENTER button (refer to 7.4), press ESC button to cancel choice and return back setup interface (refer to 7.4); |

7.4.8 Display language

| Interface | Description |
|---|---|
| <pre>---Display language--- →1:中文 2:ENGLISH 3:DEUTSCH</pre> | Press UP/DOWN button to move corresponding options. And confirm selected option and enter into the setup interface (refer to 7.4) by pressing ENTER button, press ESC button to cancel choice and return back setup interface (refer to 7.4). |

7.4.9 LCD backlight

| Interface | Description |
|--|--|
| <pre>---LIGHT TIME--- INPUT: 20 UNIT: SEC</pre> | Press UP/DOWN to increase or decrease the input figure, confirm input and return back setup interface (refer to 7.4) by pressing ENTER button, press ESC button to cancel input and return back setup interface (refer to 7.4); the input numerical value is between 20 and 120. |

7.4.10 Date/time

| Interface | Description |
|---|--|
| <pre>-----DATE/TIME----- DATE:2000-01-01 TIME: 02:43:03 WEEK: 6</pre> | Press UP/DOWN to increase or decrease the input figure; press ENTER button to move the cursor backwards, confirm input and return back setup interface (refer to 7.4); and move the cursor frontward and return back setup interface (refer to 7.4)by pressing ESC button. |

7.4.11 History clearing

| Interface | Description |
|---|--|
| <pre>--- DEL REC--- →1: CANCEL 2: CONFIRM</pre> | Clear all records in inquiry/record menu (refer to). Press UP/DOWN button to move corresponding options, and confirm the selected option and enter into setup interface (refer to 7.4) by pressing ENTER; press ESC button to cancel option and return back setup interface (refer to7.4). |

7.4.12 Password setting

| Interface | Description |
|--|--|
| <pre>----- PASSWORD ----- OLD: XXXXX NEW: XXXXX CONFIRM: XXXXX</pre> | This interface will be used to alter password when entering into the setup interface (refer to 7.4). Press UP/DOWN to increase or decrease the input figure, press ENTER button to move the cursor backwards, confirm input and return back setup interface (refer to 7.4); and move the cursor frontward and return back setup interface (refer to 7.4) by pressing ESC button. |

7.4.13 Maintenance

| Interface | Description |
|--|--|
| <pre>-----PASSWORD----- INPUT: <u>XXXXX</u></pre> | This interface will be used for factory testing, and be protected by password. |

7.4.14 Factory reset

| Interface | Description |
|--|--|
| <pre>-FACTORY RESET- →1: CANCEL 2: CONFIRM</pre> | This interface will be used to reset inverter parameter to default. Press UP/DOWN button to move corresponding options, and confirm the selected option and enter into setup interface (refer to 7.4) by pressing ENTER; press ESC button to cancel option and return back setup interface (refer to 7.4). |

7.4.15 Array detection

| Interface | Description |
|---|--|
| <pre>- ARRAY DETECT - →1: DETECT ENB 2: THRESHOLD</pre> | Press UP/DOWN button to move corresponding options, and confirm the selected option and enter into setup interface (refer to 7.4) by pressing ENTER; press ESC button to cancel option and return back setup interface (refer to 7.4). |

7.4.15.1 ARRAY

| Interface | Description |
|---|--|
| <div style="border: 1px solid black; padding: 10px; width: fit-content; margin: auto;"><p>--ARRAY-- 1: ENABLE →2: DISABLE</p></div> | Press UP/DOWN button to move corresponding options. And confirm selected option and return back Array detection by pressing ENTER button (refer to 7.4.15), press ESC button to cancel choice and return back Array detection (refer to 7.4.15); |

7.4.15.2 THRESHOLD

| Interface | Description |
|--|--|
| <div style="border: 1px solid black; padding: 10px; width: fit-content; margin: auto;"><p>--THRESHOLD-- INPUT: <u>8A</u></p></div> | Press UP/DOWN to increase or decrease the input figure, confirm input and return back Array detection (refer to 7.4.15) by pressing ENTER button, press ESC button to cancel input and return back Array detection (refer to 7.4.15); the input numerical value is between 5 and 25. |

7.4.16 Three-phase system

| Interface | Description |
|---|---|
| <div style="border: 1px solid black; padding: 10px; width: fit-content; margin: auto;"><p>--Three-phase system-- 1: 3W+N+PE →2: 3W+PE</p></div> | <p>3W+N+PE is three-phase four-wire system, 3W+PE is three-phase three-wire system;</p> <p>Press UP/DOWN button to move corresponding options, and confirm the selected option and enter into setup interface (refer to 7.4) by pressing ENTER; press ESC button to cancel option and return back setup interface (refer to 7.4).</p> |

7.5 Inquiry

| Interface | Description |
|--|--|
| <pre>-----INQUIRE----- →1: INV MODEL 2: MODEL NO 3: FIRMWARE 4: RECORD</pre> | Press UP/DOWN button to move the corresponding option, enter into the selected menu by pressing ENTER button; and return back the user interface (refer to 7.3) by pressing ESC button, there are 5 options in total, including INV MODEL, MODEL NO, FIRMWARE, RECORD And ERROR EVENT. |

7.5.1 INV MODEL

| Interface | Description |
|---|--|
| <pre>-----INVERTER----- XXXXX XXXXX</pre> | This interface displays product Model and Three-phase system. of the inverter. UP/DOWN button is invalid, ENTER button is invalid; and press ESC button to return back the inquiry interface (refer to 7.5). |

7.5.2 MODEL SN

| Interface | Description |
|---------------------------------------|---|
| <pre>-----INVERTER----- SN:</pre> | This interface displays product series No. of the inverter. UP/DOWN button is invalid, ENTER button is invalid; and press ESC button to return back the inquiry interface (refer to 7.5). |

7.5.3 Firmware

| Interface | Description |
|--|---|
| <div style="border: 1px solid black; padding: 10px; margin: 10px;"> <p>-----FIRMWARE----- ARM VER: DSP VER:</p> </div> | <p>This interface displays edition No. of firmware such as ARM and DSP in inverter. UP/DOWN button is invalid, ENTER button is invalid; and press ESC button to return back the inquiry interface (refer to 7.5).</p> |

7.5.4 RECORD

| Interface | Description |
|---|--|
| <div style="border: 1px solid black; padding: 10px; margin: 10px;"> <p>-----REC(35)----- 1:F01-1 DATE: 2011-10-21 TIME: 16:35:26</p> </div> | <p>This interface displays record and its occurring time, including two types of fault and warning alarm, its content will be described in codes, with total number of 500 at utmost, after exceeding this extent, the one with earliest time will be covered. Press UP/DOWN button to look over record backwards or frontward, and press ENTER to enter into explanation interface for corresponding record content, as shown in the following Figure. Press ESC to return back inquiry interface (refer to 7.5).</p> |
| <div style="border: 1px solid black; padding: 10px; margin: 10px;"> <p>-----DETAIL----- Grid voltage High</p> </div> | <p>This interface is used for Description for the recorded codes. UP/DOWN button is invalid, and ENTER is also invalid; press ESC button to return back to the last interface.</p> |

| | |
|----------------------------------|---|
| <pre> --- VALUE--- 285V </pre> | <p>This interface is used for displaying the corresponding specific numerical value when the code generates. For example, producing error code for Grid voltage High, and we can refer to the voltage value of the Grid at that time in this interface. Some codes correspond no numerical values, and then these interfaces are blank. UP/DOWN button is invalid, and ENTER is also invalid; press ESC button to return back the last interface.</p> |
|----------------------------------|---|

7.5.5 ERROR EVENT

| Interface | Description |
|---|--|
| <pre> -----EVE(20)----- 1:F01-1 Date: 2011-10-21 Time: 16:35:26 </pre> | <p>Press UP/DOWN button to look over record backwards or frontward, and press ENTER to enter into explanation interface for corresponding record content, as shown in the following Figure. Press ESC to return back inquiry interface (refer to 7.5).</p> |
| <pre> --EVE(1)-- +BUS: 350.0V -BUS: 350.0V RADIATOR: 50°C </pre> | <p>Press UP/DOWN button to look over record backwards or frontward, press ESC button to return back the last interface.</p> |
| <pre> --EVE(1)-- RS: 0.00Hz ST: 0.00Hz TR: 0.00Hz </pre> | <p>Press UP/DOWN button to look over record backwards or frontward, press ESC button to return back the last interface.</p> |

| | |
|--|---|
| <pre> --EVE(1)-- RS: 0.00V ST: 0.00V TR: 0.00V </pre> | <p>Press UP/DOWN button to look over record backwards or frontward, press ESC button to return back the last interface.</p> |
|--|---|

7.6 Statistics

| Interface | Description |
|---|---|
| <pre> ----- STAT. ----- →1:TIME STAT. 2:CONNE.TIMES 3:PEAK POWER </pre> | <p>This interface is used to select various options for statistics. UP/DOWN button is used to move corresponding options, press ENTER button to enter the selected menu; and press ESC to return back the user interface (refer to 7.3), there are 8 options, including time, networking number, total, that day, that week, that month, that year, power peak.</p> |

7.6.1 Time statistics

| Interface | Description |
|--|---|
| <pre> -----TIME----- RUN: 86 GRID: 56 UNIT: HOUR </pre> | <p>This interface displays operational time and generating duration of the inverter. UP/DOWN button is invalid, and ENTER is also invalid; press ESC button to return back statistics interface (refer to 7.6).</p> |

7.6.2 Times of paralleling in

| Interface | Description |
|---|--|
| <pre>--CONNE.TIMES - TIMES: 45</pre> | This interface displays times of paralleling in for the inverter. UP/DOWN button is invalid, and ENTER is also invalid; press ESC button to return back statistics interface (refer to 7.6). |

7.6.3 Power peak

| Interface | Description |
|--|---|
| <pre>-----PEAK POWER----- HISTORY: 10645 TODAY: 9600 UNIT: W</pre> | This interface displays history power peak and today power peak of the inverter. UP/DOWN button is invalid, and ENTER is also invalid; press ESC button to return back statistics interface (refer to 7.6). |

7.6.4 Generated energy of that day

| Interface | Description |
|---|--|
| <pre>-----E-TODAY ----- NUM: 100 UNIT: KWH</pre> | This interface displays generated energy of that day. UP/DOWN button is invalid, and ENTER is also invalid; press ESC button to return back statistics interface (refer to 7.6). |

7.6.5 Generated energy of that week

| Interface | Description |
|---|---|
| <pre>-----E-WEEK----- NUM: 700 UNIT: KWH</pre> | This interface displays generated energy of that week. UP/DOWN button is invalid, and ENTER is also invalid; press ESC button to return back statistics interface (refer to 7.6). |

7.6.6 Generated energy of that month

| Interface | Description |
|---|--|
| <pre>-----E-MONTH----- NUM: 3000 UNIT: KWH</pre> | This interface displays generated energy of that month. UP/DOWN button is invalid, and ENTER is also invalid; press ESC button to return back statistics interface (refer to 7.6). |

7.6.7 Generated energy of that year

| Interface | Description |
|---|---|
| <pre>-----E-YEAR----- NUM: 30000 UNIT: KWH</pre> | This interface displays generated energy of that year. UP/DOWN button is invalid, and ENTER is also invalid; press ESC button to return back statistics interface (refer to 7.6). |

7.6.8 Gross generation

| Interface | Description |
|---|--|
| <pre>-----E-TOTAL----- NUM: 100000 UNIT: KWH</pre> | This interface displays gross generation of the inverter. UP/DOWN button is invalid, and ENTER is also invalid; press ESC button to return back statistics interface (refer to 7.6). |

8. Installation

8.1 Overview

The installation introduction of inverter is as follows. Please read this chapter carefully to help you install the photovoltaic grid-connected inverter correctly.

☒ Inspection of damage during transportation

The inverter may be damaged during transportation even if we have conducted the test and detection for it before transportation. Therefore, please inspect it before installation. If any damage is detected, please contact with the transportation company or our company directly. We will provide you with the best and quickest service after you provide the photo of damaged part.

☒ Basic installation requirement

The inverter can be installed outdoors with water-proof and dust-proof level of IP65. Some basic installation requirements are as follows:

- ☒ It is the best to install it in the place where it is away from the living area due to some noise produced during its operation
- ☒ Assure there is no shake in the installation place.
- ☒ Assure that the LED light or LCD can be observed conveniently installation place.
- ☒ Assure that the ambient temperature is of $-25^{\circ}\text{C} \sim +60^{\circ}\text{C}$.
- ☒ Good ventilation is required.
- ☒ Clean installation environment is required.



Attention!

The inverter is install in the electrical restricted area, non-maintainers can't enter.

8.2 Mechanical installation

8.2.1 Installation introductions

For any live part of electronic product, the deadly dangerous may happen due to touch of it. For this product, the voltage of direct current is 1000V and the voltage of alternating current is 400V.



Attention!

The professional electrician must be invited to install this inverter.

8.2.2 Mechanical dimension

We offer the dimension of case aiming to create the convenience for your mechanical installation of inverter. The mechanical dimension: 640×841×265mm in width× height×depth.

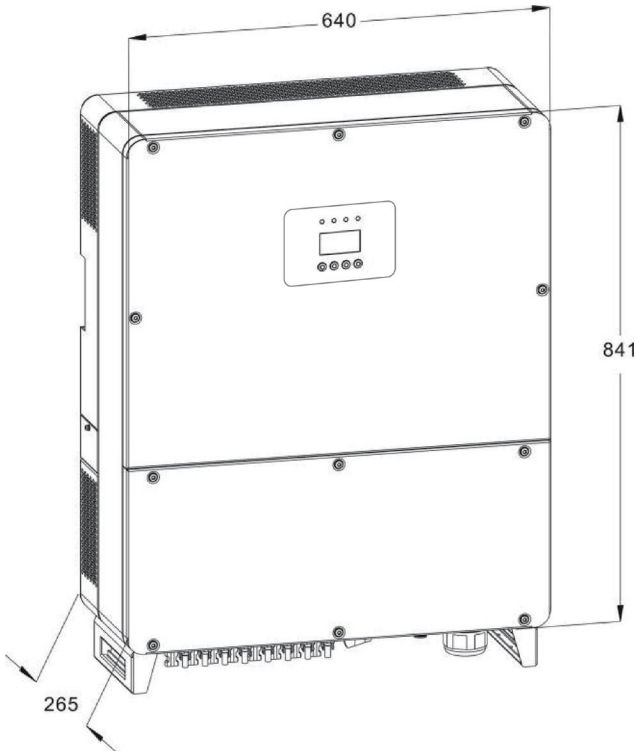

Figure 12: Dimension

8.2.3 Packing

Please check carefully before opening the package of the equipment. It may cause the inverter damage in case the packing material is found damage, please contact with forwarder for claim. If necessary, Please feel free to contact us.

8.2.4 Installation of Inverter

Please read the following installation instruction before you start your work so as to achieve best effect of the inverter.

1. In order to keep long life of inverter, the installation site should be always kept dry.
2. Select suitable location to install the inverter, where is not so easy for pedestrian to touch, but consider easy installation and easy maintenance as well.
3. Make sure the inverter should be kept at least 1M away from other stuff.
4. Don't directly expose the inverter under the sun light, high temperature will affect the inverter's working efficiency. When the temperature keeps below 45°C, the inverter will be in best working status, the life of inverter will be maximum.
5. Keep good ventilation so as to reduce heat accumulation.
6. Once installing inverter in living environment, don't mount it in plastics plate or wooden plate to avoid noise, it is better to mount it on the wall.
7. The inverter generates heat during normal working status, don't install it on a flammable objects or near the place to store flammable materials. Don't install it near potential explosion area.

8.2.5 Installation Location

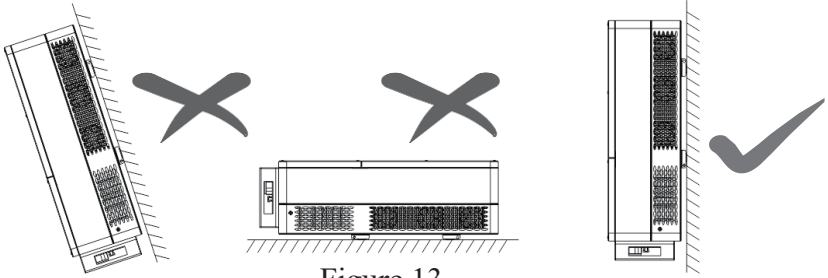

Figure 13

1. The inverter is suitable to be installed on vertical or backwards tilt wall as shown above, the tilt angle should be less 15° .
2. Don't install inverter on forward tilt wall.
3. Don't install inverter on horizontal wall.
4. Mount the inverter at height same as eyesight for easy operation and data reading.

8.2.6 Installation Procedure

●Fix the rack to metal holder (standard)

The inverter standard with bolt group (including nut, flat gasket, spring washer) before delivery. To make the inverter can be installed to various metal holder. Use $\text{Ø}12$ driller kit to drill installation holes on the metal holder according to the hole position of the rack. Then fix the rack to metal holder by using bolt group.

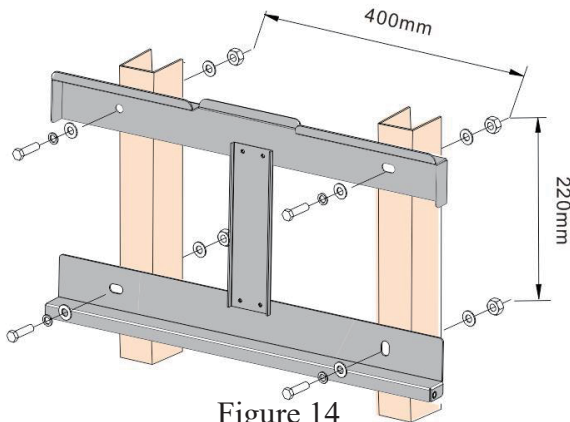

Figure 14

●Fix the rack to concrete wall (option)

1. Stick the rack from the packing list to the wall. Use $\text{Ø}14$ driller kit to drill installation holes according to the hole position of the formwork.
2. Clean the dust inside the holes, and insert expansion bolt into the holes. Make the expansion pipe into the wall, screw the bolt, take the rack, aimed at the hole, then tighten by pipe.

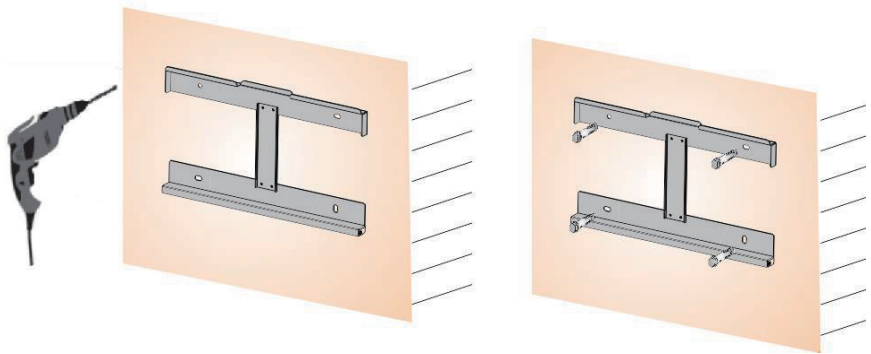

Figure 15

3. Hang the inverter to rack from the top to bottom, check both sides and keep the inverter in the right position, and tighten screws in both sides.

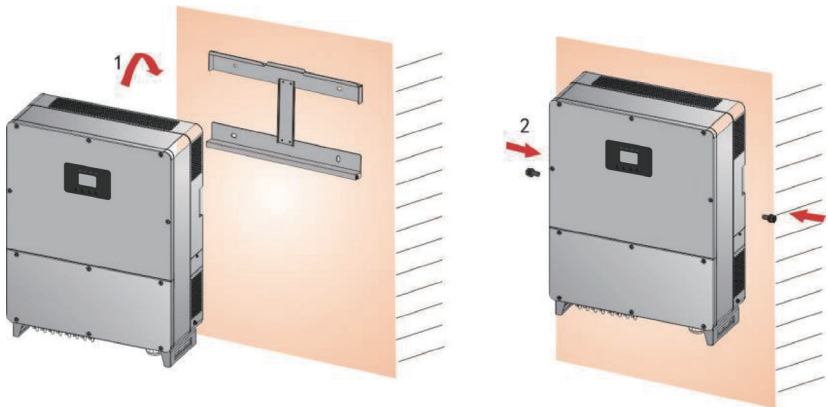

Figure 16

8.2.7 Ambient requirement



Attention!

The scope of ambient is -25°C to $+60^{\circ}\text{C}$. Meanwhile, no direct sunlight for inverter should be satisfied, or the high temperature can influence the generated energy.



Warning!

Don't place inverter with inflammable materials.



Warning!

The temperature of some parts of inverter is very high. Avoid contacting with them.

8.3 Electric connection

8.3.1 Requirement for electric installation

●Photovoltaic array

The open-circuit voltage for photovoltaic array cannot exceed 1100V.



Maximum open-circuit voltage for array: 1100V

●Three-phase grid

The grid is detected continuously by inverter to refer to whether it can meet the grid connection condition. The grid limitation for grid condition is as follows. Meanwhile, the grid-connected inverter should be installed with permit of local electric department.



Voltage of three phase grid: 180V~270V
Frequency of grid: 50/60Hz

●Connected wire

Select the inner diameter of 12AWG (4mm²) and the outer diameter of Ø5~8mm of the photovoltaic cable as the connecting line of the PV input terminal. Select the inner diameter of 2AWG-0AWG (35mm²-50mm²) and the outer diameter of Ø32~38mm of the photovoltaic cable as the connecting line of the AC output terminal. Cables should avoid high temperature, flame and rain water whenever possible. The inverter should be connected with earth permanently. The protective earthing conductor cross-sectional area is more than 10mm².

●Tools

The multimeter, wire stripper and screw driver are required during electric connection.

8.3.2 Wire for alternating current connection

- * The breaker of alternating current is cut off when wiring to assure that there is no electricity at the terminal of alternating current wire. And then, confirm it after measuring of multimeter.
- * Connect the “L1” of alternating current output with “L1” of grid;
- * Connect the “L2” of alternating current output with “L2” of grid;
- * Connect the “L3” of alternating current output with “L3” of grid;
- * 3PH, without “N”
- * The earth terminal is connected with the land via guide line.
- * Confirm that the wiring is firm.



Warning!

Assure there is no live part of inverter during electric wiring.

8.3.3 Wire for direct current connection



Warning!

The open-circuit voltage of photovoltaic array should not exceed 1100V, or the equipment will be damaged. Measure the open-circuit voltage of photovoltaic array with multimeter when connecting.



Warning!

The positive pole and negative pole of voltage for photovoltaic array cannot be reverse, which can be measured with multimeter.

- * Cut off the distribution breaker of direct current to assure that there is no live wiring of direct current.
- * Measure the open-circuit voltage for photovoltaic array with multimeter to assure that it cannot exceed 1100V.
- * Confirm the positive and negative pole with multimeter.
- * The positive pole of photovoltaic array is connected with “ PV+” of direct current input
- * The negative pole of photovoltaic array is connected with “ PV-” of direct current input.
- * Confirm that the wiring is firm.

8.3.4 Wire for communication connection

The communication method of RS485 bus is adopted for this machine when PC is used for monitoring of signal or multiple grid-connected inverters and the RJ45 terminal of terminals for inverter is the port that is used for connection of internal 485 Bus. The monitoring can be fulfilled when PC is connected with RS485 Bus via RS485/RS232 converter. The wiring diagram of communication system is in Figure 17. The diagrams for RS485/RS232 converter and RJ45 terminal and 485 bus ports are in Figure 18 and 19 respectively.

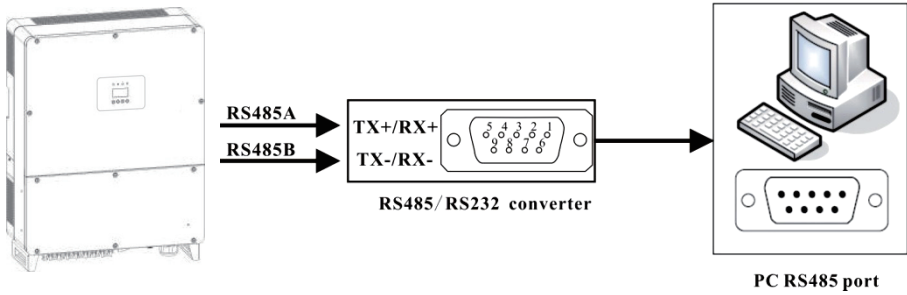

Figure 17: Communication Connection

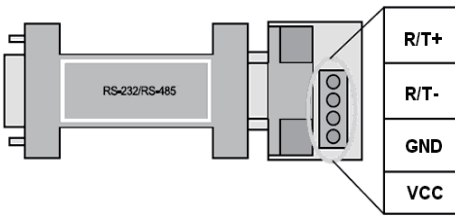

Figure 18: RS485/RS232 Converter

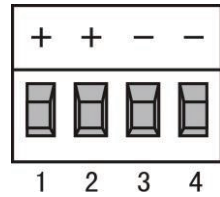

Figure 19: RS485 Port

When the GPRS/WIFI data controller monitor the PV inverter, the pin definition of GPRS/WIFI as shown in the figure20 below.

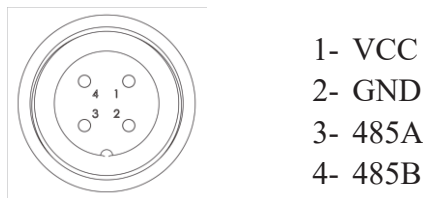

Figure 20

8.4 Starting and closing

Starting process:

1. Connect the photovoltaic array, inverter and alternating current grid correctly according to the above- mentioned installation process.
2. Measure whether the voltage of alternating and direct current meets the starting condition of machine with multimeter before starting.
3. First, close the breaker of direct current input.
4. Then, close the breaker of grid.
5. The inverter will be started automatically and combined to the grid when the conditions for normal operation of machine are satisfied.
6. The grid-connected inverter cannot be controlled manually after its normal operation and it has the functions of automatic starting and closing after fault.

Closing process:

1. The grid-connected inverter will close automatically when the solar cannot meet the requirement for generating.
2. The operation can be performed via LCD on the panel.

Closing process for emergency:

Firstly, cut off the breaker of grid and then cut off the breaker of direct current for photovoltaic array if the emergency closing is required, or the direct current breaker will be damaged and the personal hazardous will be produced. Our company cannot commit the quality assurance and bear any responsibility arising from it due to failure of complying with this requirement.

9. Technical Data

Table 9.1 Technical Data

| Model | NAC70K | NAC75K | NAC80K |
|-----------------------------------|---|-----------------|-----------------|
| Input Data | | | |
| Max. Recommended PV Power | 105000W | 112500W | 120000W |
| Max.DC Input Voltage | 1100V | | |
| MPPT voltage Range | 200-1000V | | |
| Start-up Voltage | 250V | | |
| No. of MPP Trackers | 4 | | |
| No. of Input Strings per Tracker | 3/3/3/3 | 4/4/3/3 | 4/4/3/3 |
| Max. DC Input Current | 35A/35A/35A/35A | 44A/44A/35A/35A | 44A/44A/35A/35A |
| DC Switch | Integrated | | |
| AC Output Data | | | |
| Rated AC Power | 70000W | 75000W | 80000W |
| Max.output power | 77000VA | 75000VA | 88000VA |
| Max. AC Current | 111.1A | 109A | 127A |
| Rated AC Voltage/Range | 3/PE 380, 400;+/-20%; 3/N/PE 380, 400;+/-20%; | | |
| Grid Frequency/ Range | 50Hz/60Hz ; ±5Hz | | |
| Adjustable Power Factor[cos φ] | 0.8leading ~0.8lagging | | |
| Output THDi(@Rated Output) | <3% | | |
| Efficiency | | | |
| Max.Efficiency | 99.00% | 99.00% | 99.00% |
| Euro Efficiency | 98.50% | 98.50% | 98.50% |
| MPPT Efficiency | 99.90% | 99.90% | 99.90% |
| Protection | | | |
| DC Insulation Monitoring | Integrated | | |
| Input Reverse Polarity Protection | Integrated | | |
| Anti-island Protection | Integrated | | |
| Residual Current Monitoring | Integrated | | |
| Over-heat Protection | Integrated | | |

| | | | |
|---------------------------------------|-------------------------------|------|------|
| AC Overcurrent Protection | Integrated | | |
| AC Short-circuit Protection | Integrated | | |
| AC Overvoltage Protection | Integrated | | |
| DC Surge Protection | Integrated | | |
| AC Surge Protection | Optional(Type II) | | |
| General Data | | | |
| Size(Width*Height*Depth) | 640×841×265mm | | |
| Weight | 76KG | 79KG | 79KG |
| User Interface | LCD | | |
| Communication | RS485(Standard), Wifi or GPRS | | |
| Ambient Temperature Range" | -25 °C ~ 60 °C | | |
| Relative Humidity" | 0-100% | | |
| Operating Altitude" | ≤4000m | | |
| Standby Self Consumption | <1W | | |
| Topology | Transformerless | | |
| Cooling | Fan Cooling | | |
| Protection Grades | IP65 | | |
| Noise | <60db | | |
| Warranty | 5 /7/10 years | | |
| Certifications & Standards | | | |
| Grid Regulation | PEA,MEA, IEC61727,IEC62116 | | |
| Safety Regulation | IEC 62109-1, IEC 62109-2 | | |
| EMC | EN 61000-6-2, EN 61000-6-4 | | |

Table 9.2 Grid Specification(3W+N+PE/LN)

| Grid specification | Output Voltage Range(Vac) | Output Frequency Range (Hz) | Boot wait time (S) | Error recovery time (S) |
|--------------------|---------------------------|-----------------------------|--------------------|-------------------------|
| China | 187 - 252 | 48 - 50.5 | 60 | 60 |
| Germany | 196 - 264 | 47.5 - 51.5 | 60 | 60 |
| Australia | 200 - 270 | 48 - 52 | 60 | 60 |
| Italy | 184 - 276 | 49.7 - 50.3 | 60 | 60 |
| Spain | 196 - 253 | 48 - 50.5 | 180 | 60 |
| U.K. | 184 - 264 | 47 - 52 | 180 | 60 |
| Hungary | 198 - 253 | 49.8 - 50.2 | 300 | 60 |

| | | | | |
|----------|-----------|-------------|-----|----|
| Belgium | 184 - 264 | 47.5 - 51.5 | 60 | 60 |
| AUS-W | 200 - 270 | 47.5 - 50.5 | 60 | 60 |
| Greece | 184 - 264 | 49.5 - 50.5 | 180 | 60 |
| France | 184 - 264 | 47.5 - 50.4 | 60 | 60 |
| Metro | 200 - 240 | 49 - 51 | 60 | 60 |
| Thailand | 198 - 242 | 48 - 51 | 60 | 60 |
| GB19964 | 184 - 276 | 48 - 52 | 60 | 60 |
| Local | 184 - 276 | 45 - 55 | 60 | 60 |
| 60Hz | 184 - 276 | 58 - 62 | 60 | 60 |

Table 9.3 Grid Specification(3W+PE/LL)

| Grid specification | Output Voltage Range(Vac) | Output Frequency Range (Hz) | Boot wait time (S) | Error recovery time (S) |
|--------------------|---------------------------|-----------------------------|--------------------|-------------------------|
| China | 340 - 480 | 48 - 50.5 | 60 | 60 |
| Germany | 340 - 460 | 47.5 - 51.5 | 60 | 60 |
| Australia | 340 - 480 | 48 - 52 | 60 | 60 |
| Italy | 320 - 480 | 49.7 - 50.3 | 60 | 60 |
| Spain | 340 - 440 | 48 - 50.5 | 180 | 60 |
| U.K. | 320 - 460 | 47 - 52 | 180 | 60 |
| Hungary | 360 - 440 | 49.8 - 50.2 | 300 | 60 |
| Belgium | 320 - 460 | 47.5 - 51.5 | 60 | 60 |
| AUS-W | 340 - 480 | 47.5 - 50.5 | 60 | 60 |
| Greece | 320 - 460 | 49.5 - 50.5 | 180 | 60 |
| France | 320 - 460 | 47.5 - 50.4 | 60 | 60 |
| Metro | 346 - 416 | 49 - 51 | 60 | 60 |
| Thailand | 342 - 418 | 48 - 51 | 60 | 60 |
| GB19964 | 320 - 480 | 48 - 52 | 60 | 60 |
| Local | 320 - 480 | 45 - 55 | 60 | 60 |
| 60Hz | 320 - 480 | 58 - 62 | 60 | 60 |

In the running process, errors such as AC overvoltage, AC undervoltage, AC overfrequency and AC underfrequency occur, the series go to boot wait time directly after 60 seconds when the power grid returns to normal.

10. Appendix

10.1 Quality assurance

The quality assurance for product of Our company can be conducted only on the condition that invoice and date when customer purchases the product should be presented and the trade on the product is clear during quality assurance period.

Condition

- * Our company will maintain or replace the product having fault with the new one free of charge when the fault is produced during quality assurance period.
- * The unqualified product after replacing should be returned to our company.
- * The reasonable period must be reserved by customer so that our company can repair the equipment having fault.

Our company has the right to reject the quality assurance when the following conditions appear:

- * Damage due to transportation
- * Incorrect installation
- * Incorrect refit
- * Incorrect use
- * Operate it beyond the extreme hostile environment described in this manual.
- * Install and use it beyond the scope of any provision in relevant international standard.
- * Damage due to abnormal natural environment. Please refer to the newest data if product dimension and parameter is changed without prior notice.